

Unical®

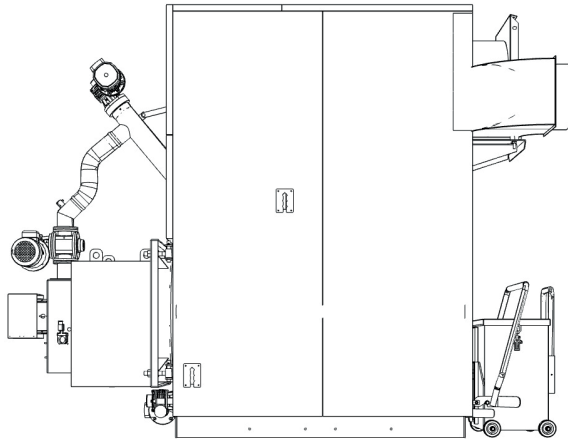

PLT 250 E

INSTRUCTIONS ON INSTALLATION, USE AND MAINTENANCE

Attention: this manual contains instructions for the exclusive use of the professionally qualified installer and/or maintenance technician in compliance with current legislation.

The user is NOT authorised to service the boiler.

The manufacturer will not be held liable in case of damage to persons, animals or objects resulting from failure to comply with the instructions contained in the manuals supplied with the boiler.

1 GENERAL INFORMATION	4
1.1 General warnings.....	4
1.2 Symbols used in the manual	5
1.3 Appropriate use of appliance.....	5
1.4 Information for user	5
1.5 Safety warnings	6
1.6 Technical data plate.....	7

2 TECHNICAL FEATURES AND DIMENSIONS	8
2.1 Technical features.....	8
2.2 Dimensions and hydraulic connections	9
2.3 Technical data.....	10
2.4 Main components.....	11
2.5 General Information.....	12

3 INSTRUCTIONS FOR THE INSTALLER	13
3.1 General warnings	13
3.2 Installation standards	13
3.3 Installation on old or retrofittable systems	13
3.4 Packaging.....	14
3.5 Handling	15
3.6 Installation.....	16
3.7 Connections	17
3.8 Hydraulic base diagrams	18
3.9 Filling the system	19
3.10 Chimney connection	20
3.11 Electrical connections.....	23
3.12 Panel board wiring diagram.....	24
3.13 Panel board	26
3.14 Starting up the boiler.....	30
3.15 Commissioning	31
3.16 Burner extinction.....	32
3.17 Instructions for technical support	32
3.18 Eliminating faults	35

4 INSPECTION AND MAINTENANCE	38
Inspection and maintenance instructions	38
Boiler body maintenance	39
Cleaning and routine maintenance	39
Extraordinary maintenance	39
Maintenance operations.....	39

1

GENERAL INFORMATION

1.1 - GENERAL WARNINGS

The instruction booklet is an integral and essential part of the product and must be kept by the system manager.

Read the warnings contained in this instruction booklet carefully as they provide important guidelines regarding installation, use and maintenance safety.

Keep the booklet with care for further consultation.

Your appliance must be installed and serviced in compliance with the standards in force according to the manufacturer instructions, up to standard and by legally qualified and certified personnel.

Systems for the production of domestic hot water MUST be constructed entirely with materials that comply with M.D. 174/2004 (taps, pipes, fittings, etc.).

By professionally qualified personnel we mean: personnel with specific technical skill in the field of heating system components for civil use, domestic hot water production and maintenance. Personnel must have the qualifications provided for by current legislation.

Incorrect installation or improper maintenance can cause damage to persons, animals or objects for which the manufacturer is not responsible.

Before performing any cleaning or maintenance, disconnect the appliance from the energy mains by acting on the switch of the system and/or through the specific cut-off devices.

Do not obstruct the terminals of the ventilation ducts.

In case of failure and/or malfunctioning of the appliance, switch it off and do not try to repair it or intervene on it directly. Contact only personnel qualified in compliance with law.

Any product repairs must be performed solely by personnel authorised by Unical, using original spare parts only. Failure to comply with the above can compromise the safety of the appliance and void the warranty.

To guarantee appliance efficiency and its correct operation, yearly maintenance must be performed by qualified personnel.

Should you decide not to use the appliance, parts entailing potential sources of hazard must be made safe.

Should the appliance be sold or transferred to a new owner or if you move and leave the appliance, always make sure that the instruction manual accompanies so that it can be consulted by the new owner and/or installer.

Only original accessories must be used for all appliances with optionals or kits (including electric).

This appliance is intended solely for the use for which it was expressly designed.

Any other use is to be considered improper and therefore dangerous.

1.2 - SYMBOLS USED IN THE MANUAL

Pay special attention when reading this manual to the parts marked by the symbols:



DANGER!
Serious danger for
personal safety and life



ATTENTION!
Possible dangerous
situation for the product
and the environment



NOTE!
Tips
for the user

1.3 - APPROPRIATE USE OF THE APPLIANCE



The appliance has been built according to the current level of engineering and recognised technical safety rules.

Nonetheless, improper use could result in hazards for the safety and life of the user or other persons, i.e. damage to the appliance or other property.

The appliance is designed to operate in hot water circulation heating systems.

Any other use must be considered improper.

UNICAL will not be held liable for any damage resulting from improper use.

Use according to the intended purposes also includes strict compliance with the instructions in this manual.

1.4 - INFORMATION FOR THE USER



The user must be instructed on use and operation of the heating system, in particular:

- Deliver these instructions to the user, as well as other documents concerning the appliance inserted in the envelope inside the packaging. **The user must keep this documentation safe for future consultation.**
- Inform the user about the importance of the air vents and the flue gas exhaust system, highlighting their essential features and the absolute prohibition of modifying them.
- Inform the user on how to control the system's water pressure as well as operations to restore it.
- Inform the user on correct temperature control, control units/thermostats and radiators for saving energy.
- Remember that the system must receive regular maintenance at least once a year and a combustion analysis must be performed every two years (as per national law).
- Should the appliance be sold or transferred to a new owner or if you move and leave the appliance, always make sure that the instruction manual accompanies so that it can be consulted by the new owner and/or installer.

The manufacturer will not be held liable in the event of damage to persons, animals or objects resulting from failure to comply with the instructions contained in this manual.

1.5 - SAFETY WARNINGS



ATTENTION!

The appliance must not be used by people with reduced physical, sensory and mental abilities, without experience and knowledge. These people must be previously trained and supervised during manoeuvre operations. Children must be supervised so that they do not play with the appliance.



ATTENTION!

The appliance must be installed, adjusted and maintained by professionally qualified personnel, in compliance with the standards and provisions in force. Incorrect installation can cause damage to persons, animals and objects for which the manufacturer cannot be held responsible.



DANGER!

The boiler must be serviced or repaired by professionally qualified personnel, authorised by Unical. We recommend stipulating a maintenance contract. Insufficient or irregular maintenance can jeopardise the operating safety of the appliance and cause damage to persons, animals and objects for which the manufacturer cannot be held responsible.



Modifying parts connected to the appliance

Do not modify the following parts:

- the boiler
- the air, water and electrical current lines
- the flue gas pipe, the safety valve and the discharge pipe
- the construction parts which affect the operating safety of the appliance



Attention!

To tighten or loosen the screwed fittings, use only appropriate fixed spanners. Incompliant use and/or inappropriate tools can cause damage (e.g. water or gas leakage).



Explosive and easily flammable substances

Do not use or store explosive or easily flammable materials (e.g. petrol, paints, paper) in the room where the appliance is installed.

1.6 - TECHNICAL DATA PLATE

The technical data plate is adhesive and is included in the document case; it must be applied by the installer on the outside of the casing.

The serial number of the boiler is on the riveted plaque on the front plate of the body (front right top side).

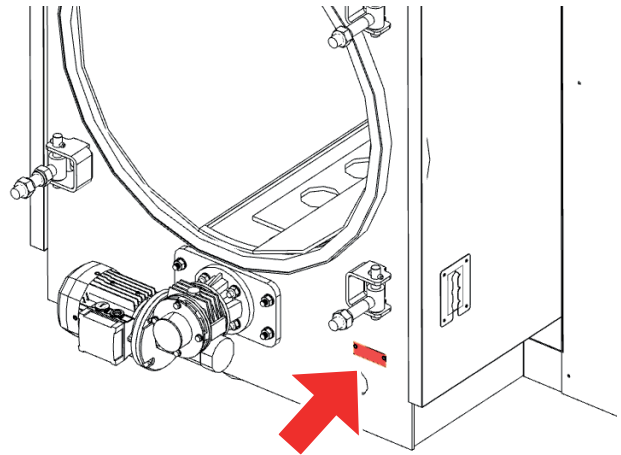

Unical®		46033 CASTELDARIO (MN) - Via Roma 123 Tel. +36 0376 57001 - Fax +39 0376 660556 www.unical.eu info@unical-ag.com	
Model	<input style="width: 100%;" type="text"/>		
S.No.	<input style="width: 20%;" type="text"/>	Year	<input style="width: 20%;" type="text"/>
	WOOD	PELLET	
Fuel type:	<input type="checkbox"/> 1	<input type="checkbox"/> 2	
Pn	<input style="width: 50%;" type="text"/> kW	<input style="width: 50%;" type="text"/> kW	
Qmax	<input style="width: 50%;" type="text"/> kW	<input style="width: 50%;" type="text"/> kW	
Adjusted Qn	<input style="width: 50%;" type="text"/> kW	<input style="width: 50%;" type="text"/> kW	
PIN	<input style="width: 50%;" type="text"/>	<input style="width: 50%;" type="text"/>	
Fuel Class:	<input style="width: 50%;" type="text"/>	<input style="width: 50%;" type="text"/>	
Boiler Efficiency: Class	<input style="width: 50%;" type="text"/>	<input style="width: 50%;" type="text"/>	
Emission Limits: Class	<input style="width: 50%;" type="text"/>	<input style="width: 50%;" type="text"/>	
	Stock <input style="width: 20%;" type="text"/> I	PMS <input style="width: 20%;" type="text"/> bar	T max <input style="width: 20%;" type="text"/> °C
	Stock <input style="width: 20%;" type="text"/> I	PMW <input style="width: 20%;" type="text"/> bar	T max <input style="width: 20%;" type="text"/> °C
	230 V - 50 Hz		A W

Symbol	Paese destino	
	EN	IT
(Model) (S.N.) (*)	Boiler Model Serial Number: See on boiler body	Modello Caldaia Matricola: vedi il numero di fabbricazione sul corpo caldaia
Year	Year of manufacturing	Anno di costruzione
(Fuel) type:	Fuel 1 - WOOD 2 - PELLET	Combustibile 1 - LEGNA 2 - PELLET
(Pn) (Qmax) (Adjust Qn)	Nominal Output Nominal Input Input adjusted at ...	Potenza Utile Nominale Potenza Termica Portata termica Regolata a ...
(CE) (PIN)	Surveillance notify body P.I.N. code	Ente di sorveglianza CE Numero Identificazione Prodotto
 (Stock) (PMS) (T. max)	BOILER data: Water content [I] Max Working Pressure Max Working Temperature	Specifiche CALDAIA Contenuto acqua calda [I] Pressione Massima Esercizio Temperatura Massima Esercizio
 (Stock) (PMW) (T. max)	D.H.W. TANK data: Water content [I] Max Working Pressure Max Working Temperature	D.H.W. TANK data: Contenuto acqua calda [I] Pressione Massima Esercizio Temperatura Massima Esercizio
	Electrical supply	Alimentazione Elettrica
EN 303-5 Classification	Fuel Class Boiler Efficiency Emission Limits	Classe Combustibile Classe di Efficienza Classe di Emissioni

TECHNICAL FEATURES AND DIMENSIONS

2.1 - TECHNICAL FEATURES

The heat generator mod. **PLT 250 E** is a steel boiler operating with wood pellets, with combustion chamber under negative pressure.

The **PLT 250 E** boiler is complete with all the safety and control devices required by the standards.

DESCRIPTION OF COMPONENTS:

- Steel boiler body
- Steel burner
- Vertical smoke ducts
- Loading front door with refractory insulation
- Lower door covered with insulation
- Lower rear door for special cleaning, covered with insulation
- Top smoke chamber with inspection door and ash removal door
- Flue gas evacuation with intake fan
- Boiler body insulated with 80 mm thick mineral wool panels
- Powder painted sheet steel casing
- Compressed air buildup tank
- Pellet shut-off rotary valve
- Burner automatic cleaning system

PANEL BOARD COMPONENTS:

- Main switch with light indicating presence of voltage
- Safety thermostat for boiler overheating
- General fuse
- Display

Heat generator for hot water production aimed at heating for civil, public, industrial and agricultural uses

- Ideal for conversion of systems operating with fossil fuels such as diesel, gpl, other
- Fully automatic with standard equipment: combustion head pneumatic cleaning system, vertical smoke pipes exchanger mechanical operation, ash removal, ash compactor
- Suited for wood origin pelletised solid granular biomass fuel

- Very high efficiency beyond 93%
- CLASS 5 according to EN 303-5/2012
- Burner with fan downstream of the combustion chamber, automatic ignition system with horizontal flame development
- Burner automatic cleaning kit operated via high pressure compressed air
- Safety rotary valve against flame return, with sector single chamber closed impeller positioned between burner and pellet loading duct
- Stainless steel blast tube withstanding thermochemical stresses
- Stainless steel gasification grate
- Flame modulation combustion suction fan controlled by inverter electronic system
- High efficiency heat exchanger, with vertical smoke pipes, with automatic cleaning via steel turbulators
- Boiler body isolation and mineral wool vertical exchanger, with 80 mm high thickness
- Rear smoke chamber with 300 mm chimney fitting, which may be positioned on the left, right or top side Set-up for dusts separation
- Combustion chamber doors covered in refractory material 100 mm thickness and reversible opening
- Combustion chamber negative pressure continuous checking pressure switch
- Thermostat for checking temperature of the fuel loading and safety manual reset duct
- Photoresistor for checking flame presence
- Compressed air storage tank with 50 litres capacity fitted with bottom drain valve, flexible hose for burner connection, safety valve
- Console mounted panel board which may be positioned on boiler sides fitted with LED indicators for alarms and operating status
- Programmable integrated microprocessor for combustion and standard functions management. System pumps control, fuel loading management remote alarm contacts DHW production, from remote deposit
- Service pellet incorporated tank, with 150 kg pellet capacity - feeding screw sloped stainless steel spiral
- Flange housing set-up for remote deposit pellet automatic loading metering device
- Ash compactor with removal

2.2 - HYDRAULIC DIMENSIONS AND CONNECTIONS

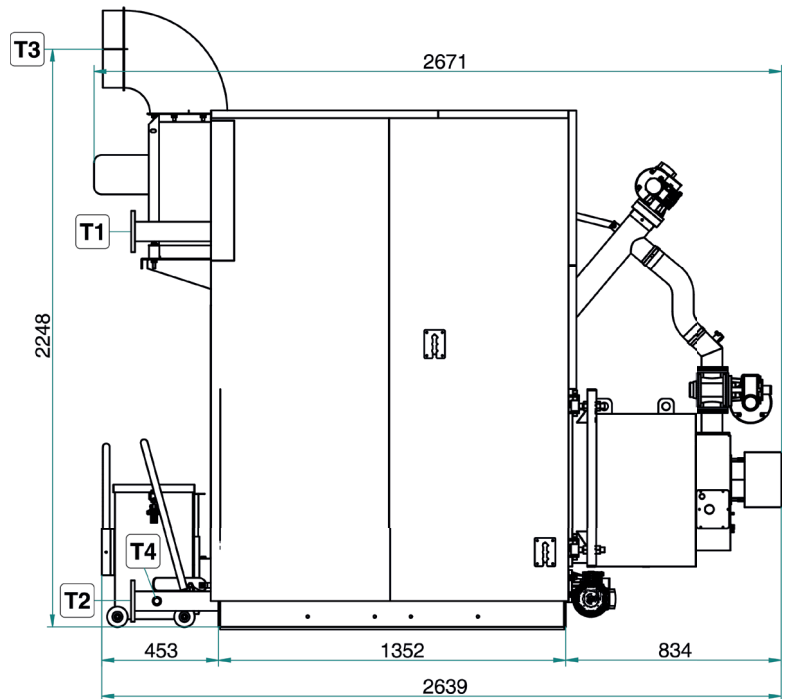
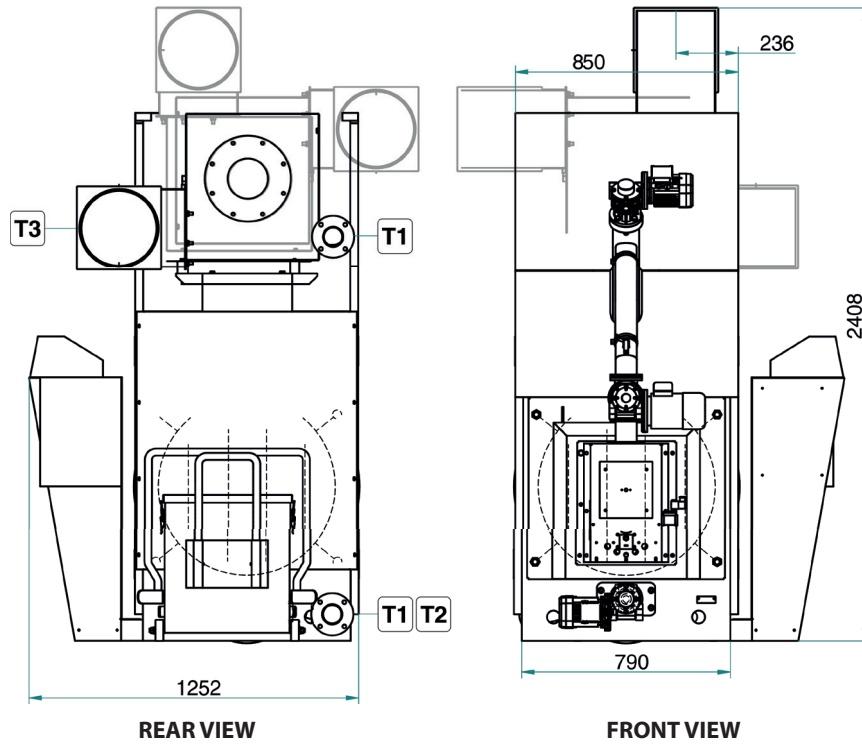

- | | | |
|----|--|------|
| T1 | SYSTEM FLOW | DN65 |
| T2 | SYSTEM RETURN | DN65 |
| T3 | CHIMNEY CONNECTION \varnothing_e 300 | |
| T4 | BOILER DRAIN G 3/4" | |

Flue gas outlet fan positioning (rear view)

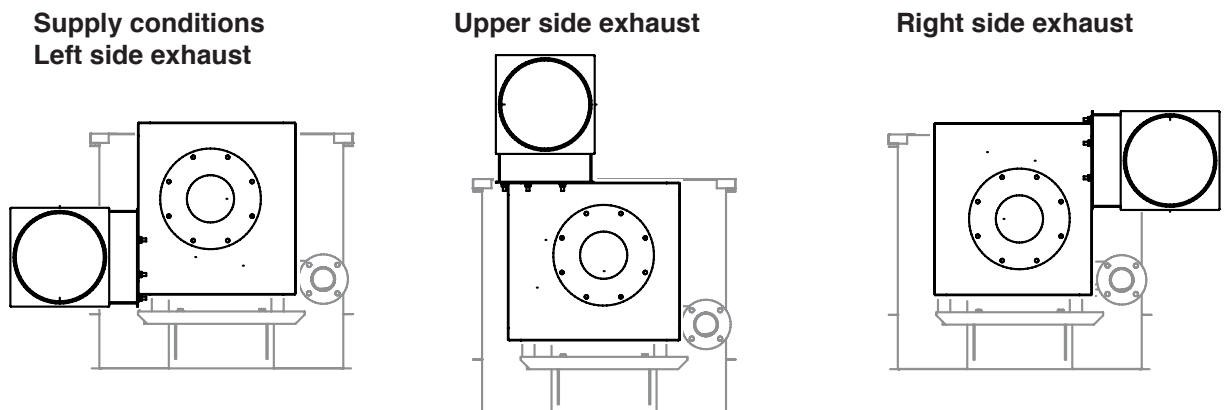

2.3 - TECHNICAL DATA

MODELS		PLT 250
MIN/MAX NOMINAL POWER	(kW)	71/227.6
FURNACE MIN/MAX OUTPUT	(kW)	76.3/250.2
EFFICIENCY	(%)	93.11/90.97
O ₂	(%)	9.6/7.1
CO ₂	(%)	10.4/13.0
CO 10%	(mg/Nm ³)	15.4/46.8
CO 13%	(mg/Nm ³)	11.2/34
NO _x 10%	(mg/Nm ³)	176.3/240.4
NO _x 13%	(mg/Nm ³)	128.2/174.8
Hc 10%	(mg/Nm ³)	7.7/9.36
Hc 13%	(mg/Nm ³)	5.6/6.81
Dust 10% (nominal output)	(mg/Nm ³)	18/18
Dust 13% (nominal output)	(mg/Nm ³)	13/13
MAX OPERATING PRESSURE	(bar)	6
MINIMUM DRAUGHT REQUIRED BY CHIMNEY	(Pa)	15
MIN. FLOW TEMPERATURE	(°C)	75
MAX. FLOW TEMPERATURE	(°C)	85
MIN. RETURN TEMPERATURE	(°C)	55
WATER SIDE PRESSURE DROPS (10K)*	[mbar]	11.2
WATER SIDE PRESSURE DROPS (20K)*	[mbar]	2.8
COMBUSTION AUTONOMY	(h)	4
PELLET STORAGE VOLUME	(l)	210
PELLET STORAGE CAPACITY	(kg)	126
DIMENSIONS OF THE LOADING DOOR	(mm)	- - -
Pellet CONSUMPTION Q _n /Q _{min}	(kg/h)	50.0/15.3
MAX. HEATABLE VOLUME **	(m ³)	6524
FLUE GAS TEMPERATURE Q _n	(°C)	154
MIN-MAX FLUE GAS MASS FLOW RATE	(kg/s)	0.049/0.128
BOILER WATER CONTENT	(l)	325
EMPTY BOILER WEIGHT	(kg)	1570
MAXIMUM OUTPUT ABSORBED Q _n /Q _{min} ***	(W)	1350/1000
OUTPUT ABSORBED IN STAND-BY ***	(W)	8.3
OUTPUT ABSORBED IN IGNITION ***	(W)	2155
NOISE LEVEL	(dB)	<55
BOILER CLASS ACCORDING TO EN 303-5		5
FUEL CHARACTERISTICS		See par. 2.6
THERMAL STORAGE VOLUME (Recommended)	(l)	
BOILER OPERATION		WITH FAN
COMBUSTION CHAMBER OPERATION		UNDER NEGATIVE PRESSURE
OPERATION IN CONDENSATION		NO

* Pressure drops for flow rate corresponding to a thermal drop of 15K.

** Values calculated based on the Law 10/91 for residential homes with a heat requirement of 30 kcal/hm³. The data shown is indicative.

*** Without the aid of external pumps

The results in the table have been obtained using certified pellets based on the standards EN 14961-2.

2.4 - MAIN COMPONENTS

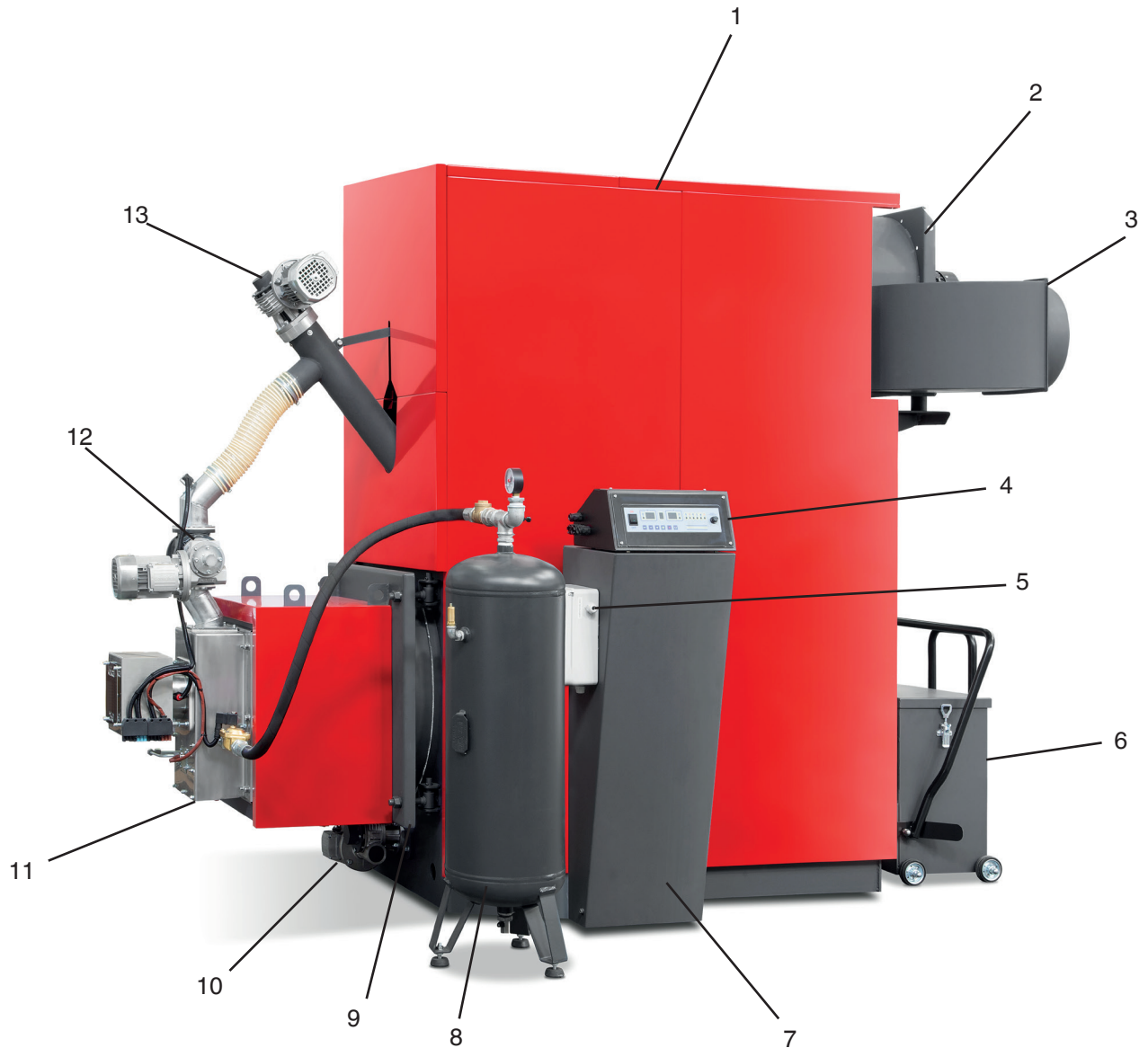

1. Casing
2. Fan
3. Flue gas exhaust connection
4. Burner electrical panel
5. Contactors electrical box
6. Ash compactor box
7. Console mounted panel support
8. Compressed air tank
9. Burner door
10. Ash cleaning feeding screw motor
11. Burner
12. Rotary valve
13. Loading feeding screw
14. Automatic load metering device (optional)
15. Pellet tank
16. Smoke chamber
17. Smoke pipes cleaning system motor

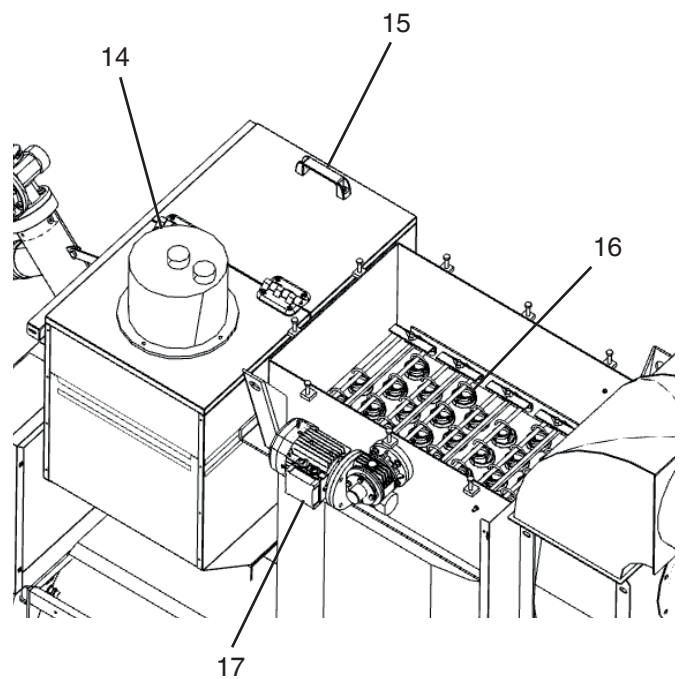

2.5 - GENERAL INFORMATION

The main feature of the PLT 250 boiler is that of burning natural fuel (pellets) obtained in an environmentally-friendly way from wood industry waste (sawdust, powders). The sawdust and powders coming from wood processing, after having been appropriately cleaned and dried, are compacted at high pressure to create pure wood cylinders: pellets.

The main features of the pellet are its low moisture content (lower than 10%), its high density (> 600 kg/m³) as well as its

regularity and compactness providing this type of fuel a high Net Calorific Value.

In order to provide PLT with a long lifespan, Unical advises using certified pellets.

The pellets used to feed the boiler must have high quality features such as, for example, those determined by the standard EN 14961-2. The following are some of their fundamental data.

Parameter	M.U.	EN plus-A1	EN plus-A2
Diameter	mm	6 (± 1)	
Length	mm	31.5 ≤ L ≤ 40 ⁴	
Water content ²	%us ²	≤ 10	≤ 10
Ashes ³	%db ³	≤ 0.7	≤ 1.2
Mechanical durability ²	%us ²	≥ 98.0 ⁵	≥ 97.5 ⁵
Dust (< 3.15 mm) ²	%us ²	≤ 1.0 ⁶ (≤ 0.5 ⁷)	≤ 1.0 ⁶ (≤ 0.5 ⁷)
Lower Calorific Value ²	MJ/kg us	≥ 4.6 ⁸	≥ 4.6 ⁸
Bulk density ²	kg/m ³ ²	600 ≤ BD ≤ 750	600 ≤ BD ≤ 750
Nitrogen (N)	%db ³	≤ 0.3	≤ 0.5
Sulphur (S)	%db ³	≤ 0.04	≤ 0.05
Chlorine (Cl)	%db ³	≤ 0.02	≤ 0.02
Ash softening temperature ¹	°C	≥ 1200	≥ 1100
Arsenic (As)			
Cadmium (Cd)	mg/kg ³	≤ 1	≤ 1
Chromium (Cr)	mg/kg ³	≤ 0.5	≤ 0.5
Copper (Cu)	mg/kg ³	≤ 10	≤ 10
Lead (Pb)	mg/kg ³	≤ 10	≤ 10
Mercury (Hg)	mg/kg ³	≤ 10	≤ 10
Nickel (Ni)	mg/kg ³	≤ 0,1	≤ 0,1
Zinc (Zn)	mg/kg ³	≤ 10	≤ 10
	mg/kg ³	≤ 100	≤ 100

1) ash produced at 815°C

2) us = unaltered state

3) db = dry base

4) maximum 1% of pellet may exceed the length of 40 mm. Pellet with a length equal or higher than 45 mm is not allowed.

5) the more restrictive parameter of the standard ISO 17225-2

6) in case of bulk product

7) in case of pellets in bags

8) equal to ≥ 16.5 MJ/kg in unaltered state



The pellets, as foreseen by current Italian legislation governing commodity features of fuels (DPCM 2.10.1995), must be produced exclusively with untreated wood sawdust without other materials added.

- Pellets must be moved in such a way to avoid excessive crushing into fine powders.

Compliance with these two simple rules provides better combustion efficiency and conserves the moving mechanical parts of the appliance.



It is strictly forbidden to use any solid or liquid fuel other than pellets to feed the boiler.



If you plan on not using the boiler for a long period of time (7 days or more), you must remove any residual fuel in the tank which, if left inside, could gather moisture and cause the product to malfunction.



It is advisable to use certified pellets to ensure optimal use of the boiler. The use of poor quality pellets may cause boiler malfunctioning and shall terminate the warranty.



A high moisture content in the pellet can cause it to break up into powder generating a greater accumulation of residue in the brazier and a blocking of the fuel feed system (feeding screw).

Storage and handling of pellets are important operations to be performed with care:

- The fuel must be stored in a dry place which is not cold;

INSTRUCTIONS FOR INSTALLATION

3.1 - GENERAL WARNINGS



ATTENTION!

This boiler is intended solely for the use for which it was expressly designed. Any other use is to be considered improper and therefore dangerous.

This boiler heats water at a temperature lower than the atmospheric pressure boiling temperature.



ATTENTION!

The appliances are designed to be installed inside suitable rooms or technical spaces only. The appliances cannot be installed or operate outdoors. Outdoor installation can cause malfunctioning and be dangerous. Choose specifically designed appliances for outdoor installation.



Before connecting the boiler, have professionally qualified personnel:

- a) Thoroughly wash all the piping of the system to remove any residue or impurities which could jeopardise proper operation of the boiler;

- b) Check that the chimney/flue has an appropriate draught, without any bottlenecks, and that no exhausts from other appliances are inserted, unless the flue has been implemented to accommodate several utilities according to specific standards and prescriptions in force. Only after this check can the fitting between the boiler and chimney/flue be mounted;



ATTENTION!

The appliance must be installed by a qualified technician with the technical-professional requirements according to law 37/08 which, under his own responsibility, guarantees compliance with the standards according to good practice rules.



The boiler must be connected to a central heating system and/or domestic hot water production network compatible with its efficiency and output.

3.2 - INSTALLATION STANDARDS

It must be installed by a professionally qualified technician, who shall take the responsibility of observing all local and/or national laws published in the Official Journal, as well as applicable technical standards.

3.3 - INSTALLATION ON OLD OR RETROFITTABLE SYSTEMS

Before installing this appliance on old systems, check that:

- The chimney is able to withstand the temperature generated by the combustion products, has been measured and designed according to the regulations in force, is airtight and insulated, and does not have any obstructions or constrictions.
- The chimney has a connection for draining condensation.
- The electrical system has been set up by a qualified technician in compliance with the rules in force.
- The rate, head and direction of the flow of the circulation pumps are appropriate.
- The expansion vessel(s) can fully absorb dilation of the fluid in the system.
- The expansion vessels can fully absorb dilation of the fluid in the system.
- The system has been cleaned and cleared of all sludge and scale, has been vented, and all of its seals have been checked.
- There is a treatment system for feed/recirculation water.

3.4 - PACKAGING

The PLT 250 boiler is delivered already encased, protected by a wood crate and heat shrink plastic film.



The manufacturer shall not be held liable for damage to persons, animals or property due to failure to comply with the instructions above.



After having removed all packaging, make sure that the supply is complete and undamaged. If in doubt, do not use the appliance and contact the supplier.



Keep the packaging material (cardboard boxes, straps, plastic bags, etc.) out of the reach of children as they are potential sources of danger.

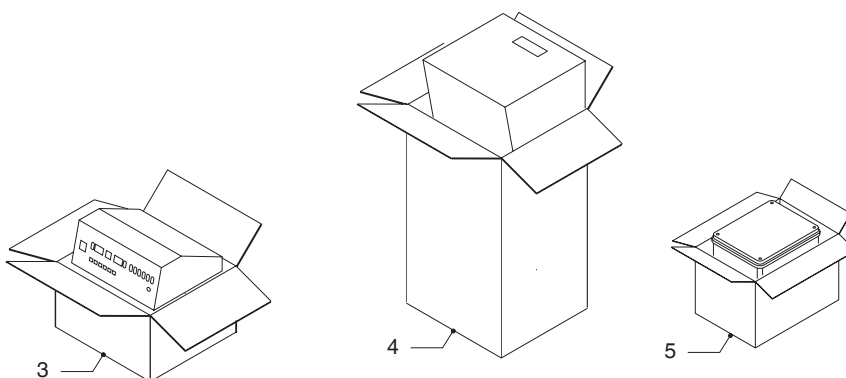
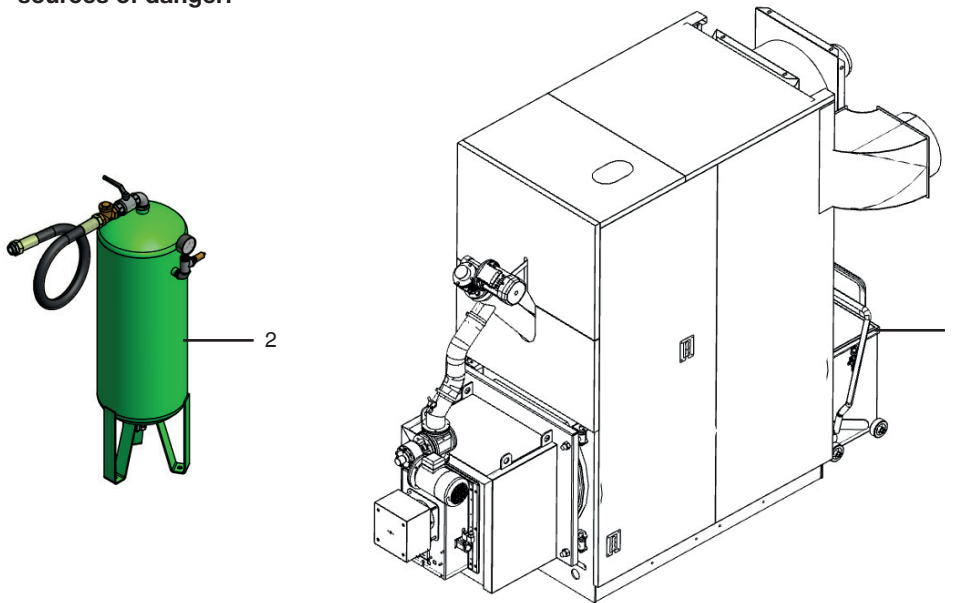

Description of packs:

1. Boiler body
2. Compressed air tank
3. Package containing the panel board
4. Package containing the console mounted instruments panel
5. Package containing contactors electrical panel

The document envelope, inserted in the furnace, contains:

- Hydraulic test certificate
- Installation and maintenance instruction booklet
- Warranty
- Technical data adhesive plate



If the boiler is stored for long periods, it should be adequately protected.

3.5 - HANDLING

To handle the boiler and remove the pallet below, specific lifting hooks are set up on the upper boiler part.

Lift the boiler using specific lifting equipment, hooking it to the two rings set up on the smoke chamber.



Unical shall not be held liable for damage to persons, animals or objects due to failure to comply with the instruction above.

Operating the release lever (1), remove the ash compactor box (2)

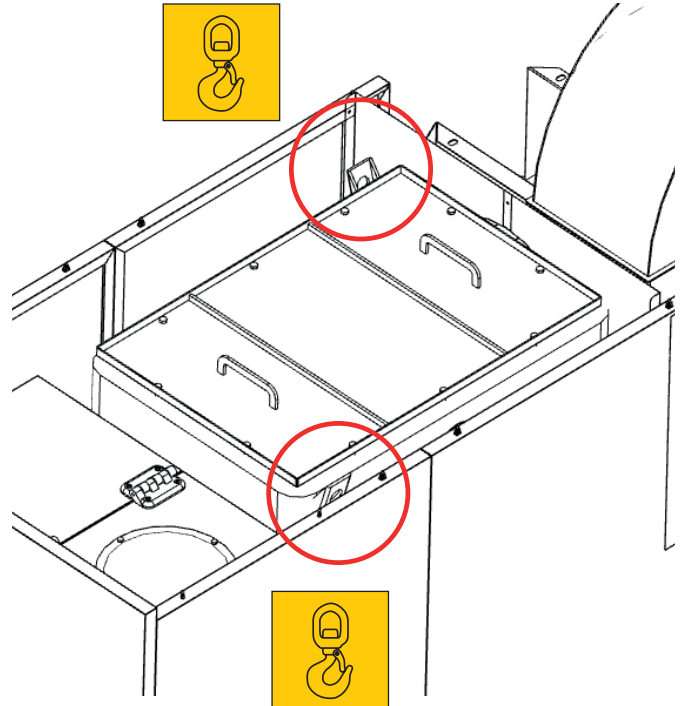
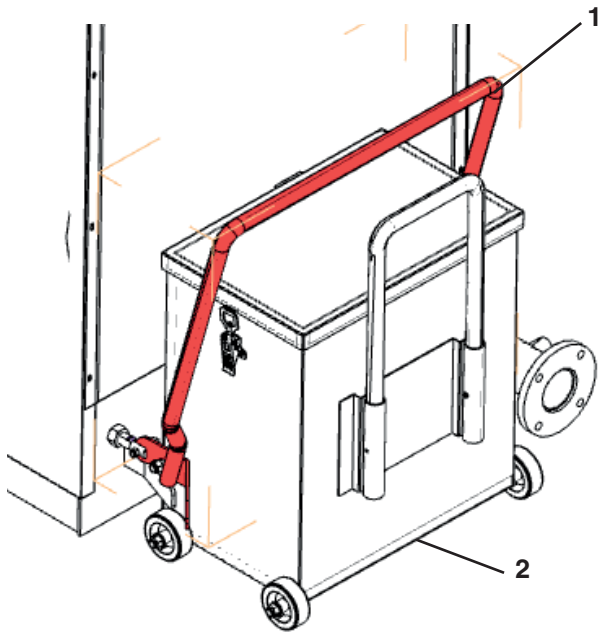

Remove the upper casing (3)

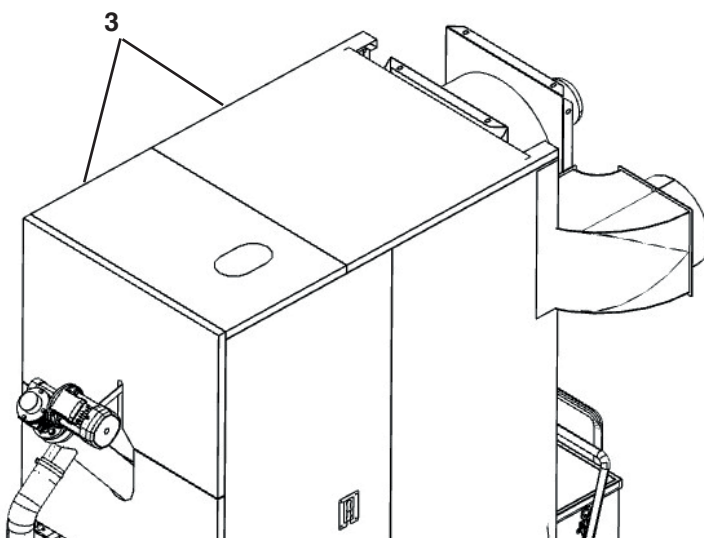

3.6 - INSTALLATION

The PLT 250 is a heat generator which withdraws the combustion air required for the combustion process directly from the environment in which it is installed.

For this reason, and above all for the safety of the persons using the PLT 250, it must be installed in a ventilated area so that a continuous flow of combustion air is always guaranteed.

It is therefore essential to make air vents linked with the outside which, in compliance with that indicated by Standard UNI 10683, have the following features:

1. A free section of 100 cm or more², or regardless preventing pressure in the installation area from exceeding 4 Pa;
2. Be made close to the floor;
3. Be appropriately protected by metallic mesh or grille so that the minimum air passage cross-section is not reduced;
4. Be positioned in such a way that it cannot be obstructed.



The correct air influx can also be guaranteed by using openings towards an adjacent room as long as that room is provided with direct ventilation and that it is not a room with a fire risk such as depots, garages or storerooms as regulated by standard UNI 10683.

PLT 250 should be installed in spaces without natural draught equipment or equipment which may create a vacuum in the room in relation to the outside environment and therefore hinder the draught of the flue gas exhaust system (UNI 10683).

To make it easier to clean, there must be a clearance space in front of the boiler no less than the length of the stove itself. You must at least make sure that the door can open 90° unobstructed.

The PLT 250 can be placed directly on the floor as it is equipped with a self-supporting frame.



When inspecting compatibility of the heating system, you should make sure that the support surface (floor) has a support capacity (kg) suitable to bear the weight of the product. If it is not adequate, suitable safety measures should be taken (e.g. load distribution plate).

Furthermore, should the floor be made of combustible material (such as parquet) it should be protected by using a sheet of fireproof material underneath the PLT 250 sufficiently wider than the base.

When installation is complete, the boiler must be horizontal and stable, in order to reduce vibrations and noise.

However clearance space must be left behind the boiler and on both sides to allow the casing to be opened for maintenance.

There must also be sufficient clearance for loading the pellet tank.

Do not approach or touch the outer surfaces of the combustion chamber with flammable material as it can reach high temperatures following continuous use.

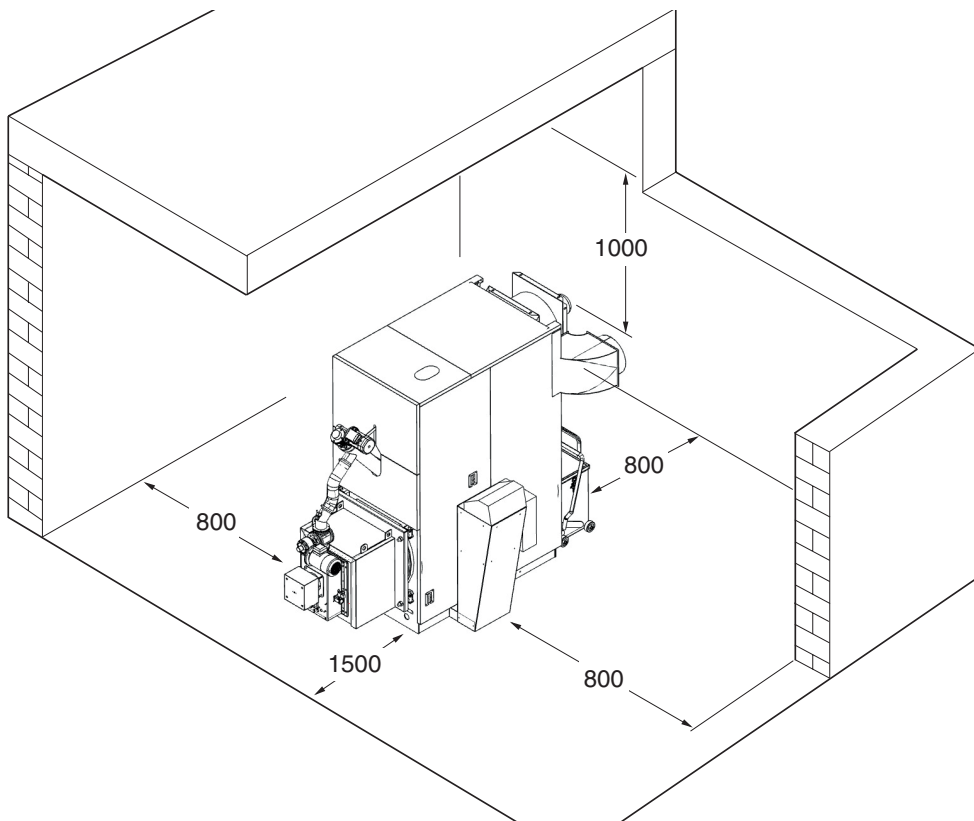

3.7 - CONNECTIONS

3.7.1 - HYDRAULIC CONNECTIONS



ATTENTION!

Before connecting the boiler to the heating system, thoroughly clean the piping with an appropriate product compliant with UNI-CTI 8065, in order to eliminate metallic residue from processing and welding, oil and grease which could be present and which, reaching the boiler, could alter its functioning.



Attention!

The fittings of the boiler must not take the weight of the connecting pipes of the system; suitable supporting devices should be installed to do this.

The dimensions of the supply and return pipes for each boiler model are given in the DIMENSIONS table.

Check that the system is fitted with a sufficient number of vent valves.

3.7.2 - THERMAL DISCHARGE VALVE CONNECTION

Solid fuel fired boilers must be installed with the safety devices foreseen by the relevant laws in force.



A thermal discharge valve shall be mounted by the installation technician.



Attention!

If this precaution is not taken, triggering of the thermal discharge valve can cause damage to persons, animals and objects for which the manufacturer cannot be held responsible.

3.7.3 - RECIRCULATION PUMP

For correct generator operation, a recirculation pump must be installed in the boiler.
If it is not installed, besides limiting the boiler's lifespan, it will invalidate the warranty.

3.7.4 - PNEUMATIC CONNECTION

The burner is equipped with an automatic cleaning system, therefore burner pneumatic connection to the compressed air container must be performed.

- The compressed air storage tank must be connected between the burner and an air compressor.
- The compressor must be able to generate an operating pressure between 4 and 5 bar.
If the pressure is greater than 5 bar, set up a pressure reducer.
- The tank is already set up to be connected via connected flexible hoses.

To enable correct operation of the burner the buildup station must be powered up with dried and appropriately filtered compressed air. Should these factors not be present the cleaning kits may not operate correctly, limiting the efficiency and functionality of the burner.

The compressor and the tank must be positioned at a safe distance from the thermal unit, away from heat sources and from the fuel service tank.

Compressed air buildup tank

The compressed air storage tank has been designed for the burner automatic cleaning system operation. The storage tank must be connected between the burner and an air compressor via the connected flexible hose supplied.

The tank is fitted with pressure gauge, safety valve, bottom discharge valve and flexible hose for connection to the burner automatic cleaning system.

Technical data

Boiler	l	50
Max. operating pressure	bar	11
Tank conformity	directive	2009/105/EC
Safety valve conformity	directive	97/23/EC
Safety valve calibration	bar	10
DN 63 Pressure gauge	bar	0--10

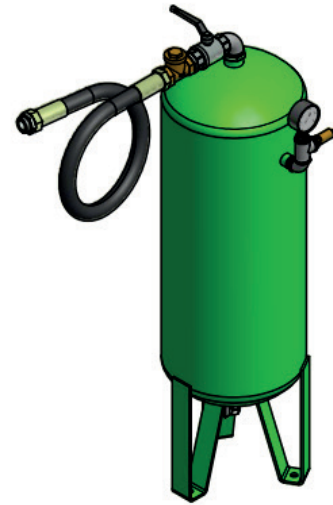

Tank and safety valves certifications are attached to the tank.

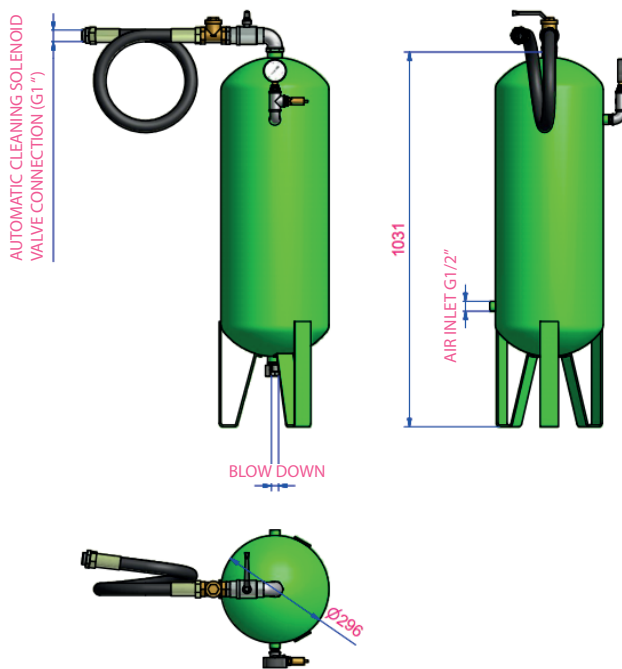

Burner automatic cleaning system

The burner is equipped with an automatic cleaning system, to keep the burner gassification area clean and for correct combustion without changes in the air/fuel ratio.

The system is fully automatic and controlled by the micro-processor equipped on the electronic board for managing the burner logic.

The system consists of a compressed air dispenser installed inside the burner, a 2-way compressed air shut-off solenoid valve with direct control of the electronic board, with the option of supplying air from both the left and right, in order to follow the opening of the boiler door. Therefore it is required to perform the pneumatic connection of the burner to the compressed air container.

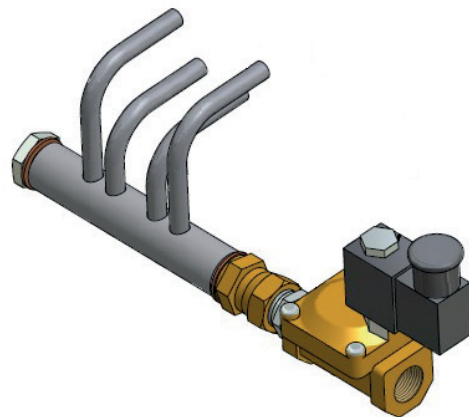

TECHNICAL DATA

Power supply voltage	230 V – 50 Hz
Electrical power	5 W
Max. operating pressure	3 bar

3.8 - HYDRAULIC BASE DIAGRAMS

The following diagrams are for reference only and therefore are not binding. Unical declines any responsibility for errors or omissions.

3.8.1 - SYSTEM WITH PLT MODEL BOILER FOR HEATING

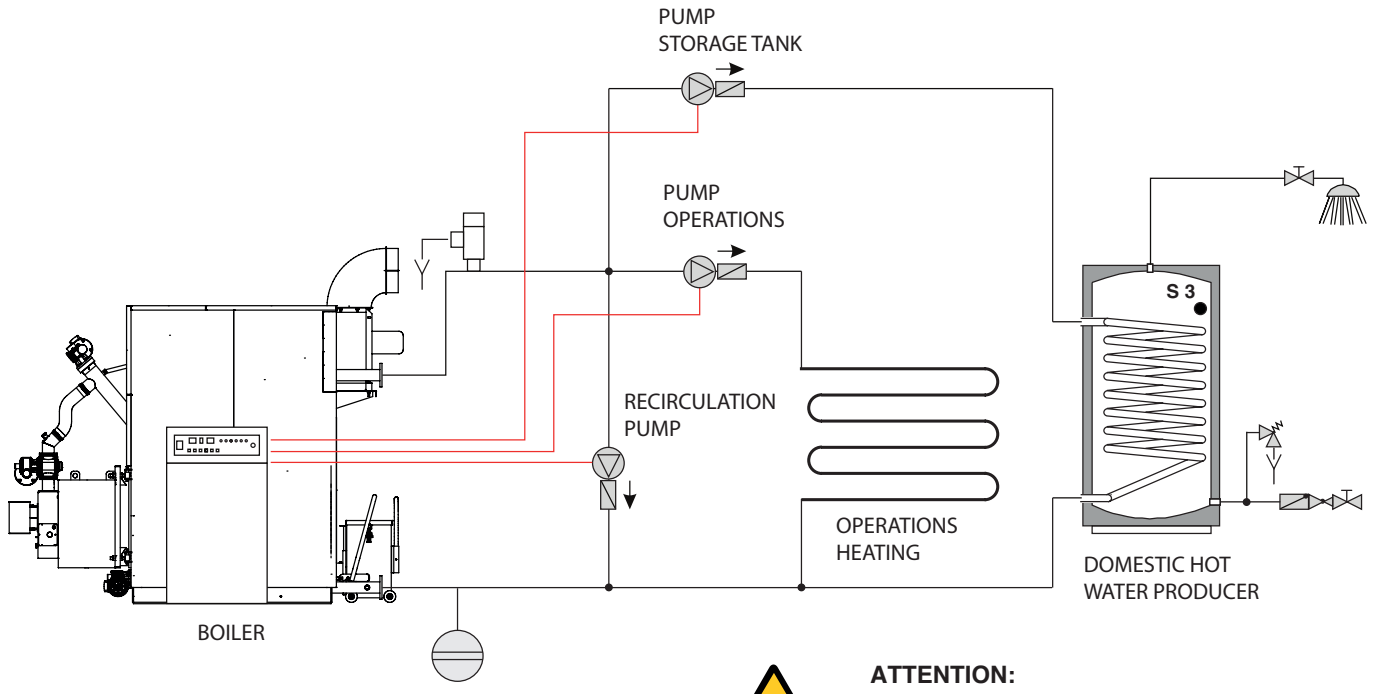

ATTENTION:

In the case of a system with closed expansion vessel, the installer must assemble a minimum/maximum water pressure switch and the safety heat exchanger.

3.9 - FILLING THE SYSTEM



NOTE

Before filling the system, check the preload of the expansion vessel which must be 1.5 bar, and adjust it if the pressure is any less. In systems equipped with a closed expansion vessel, the water pressure in the heating system - with the system cold - must not drop below 1 bar; open the filling tap when the pressure is too low. This operation must be performed with a cooled system. The pressure gauge fitted on the system allows you to read the circuit pressure.



Attention!

Do not mix the heating water with incorrect concentrations of antifreeze or anti-corrosion substances! This could damage the gaskets and cause noise during operation. Unical will not be held liable for damage to persons, animals or objects due to failure to comply with the instruction above.



After making all the water connections, fill the boiler to check the tightness of all the connections.

This operation must be performed carefully, respecting the following phases:

- open the bleeder valves of the radiators, radiant batteries and/or distribution manifolds;
- open the system filling tap gradually, making sure that the automatic air release valves installed on the system work properly;
- close the bleeder valves of the radiators, radiant batteries and/or distribution manifolds as soon as water comes out;
- check the pressure gauge until pressure reaches approximately 1 bar;
- close the system filling tap and bleed air once again through the bleeder valves of the radiators, radiant batteries and/or distribution manifolds;
- make sure that all the connections are water-tight;
- after commissioning the boiler and bringing the system to the operating temperature, stop the pumps and repeat the air bleed operations;
- let the system cool off and, if necessary, return the water pressure to 1 bar.

3.10 - CONNECTION TO THE CHIMNEY

To connect the flue gas exhaust pipe, local and national standards must be observed.

The chimney is essential to good boiler operation: accordingly, the chimney needs to be water-proof and well-insulated.

Old or new chimneys, built without respecting the specific requirements, can be recovered by “piping” the chimney itself.

It will be necessary to introduce a metallic pipe inside the existing chimney and insulate the space between the metallic pipe and the chimney.

Chimneys made of prefabricated blocks must have perfectly sealed joints to avoid that flue condensate smudging the walls due to permeation.

The entrance to the chimney should be at a 45° angle.

At the base of the chimney a flue inspection opening has to be made.

It is recommended to insulate the pipe connecting to the chimney to reduce heat loss and noise.

The dimensions of the chimney must guarantee the draught required to properly operate the boiler.

An insufficient draught, besides causing smoke leakage, considerably reduces the heat output. On the contrary, an excessive draught causes an abnormal heat output increase, a higher flue gas temperature in the chimney and too much fuel consumption.

- A weatherproof and windproof terminal must be used to avoid changing the slight state of overpressure of the chimney (do not fit a horizontal section at the end of the chimney);
- The exhaust ducts must be made with material resistant to combustion products and condensation (the inspection valve can drain any condensation which may be formed);
- Pipes must be built in such a way to guarantee maximum smoke tightness (UNI 10683);
- It is recommended to insulate the piping, especially the outside part exposed to foul weather.

Do not make sections fully horizontal.

There must be no flue gas exhaust hoods installed or already existing in the room where the heat generator is installed to avoid creating a vacuum in the environment.

It is prohibited to close the air vents.

Have the flue cleaned at least once a year; we therefore recommend having both the chimney and the flue gas fitting thoroughly cleaned.



Use only exhaust pipes suitable for the type of fuel used.

The supplier will have no contractual or extra-contractual liability for damage caused due to incorrect installation and use and anyway failure to comply with the instructions provided by the manufacturer.



It is prohibited to exhaust PLT combustion products in shared smoke pipes.



The chimney must comply with the standards in force.

The flue gas chimney must be made properly to favour the normal flow of flue gas from the combustion chamber towards the outside in the case of a power outage.

Remember that the elimination of excess heat is managed optimally by the electronic control unit.

The following are the main features of the flue gas exhaust pipe according to that established by standards UNI 7129 and UNI 10683:

- The flue gas exhaust must be equipped with waterproof inspection openings
- The minimum height of the pipe connected directly to the flue gas exhaust is between 2-3 m;
- If a horizontal section is inevitable, it is recommended that it be no longer than 1.5 m at most and sloping 3÷5% to favour the escape of the flue gas;



Should the flue or piping catch fire, immediately switch the boiler off and disconnect it from the household electrical mains.

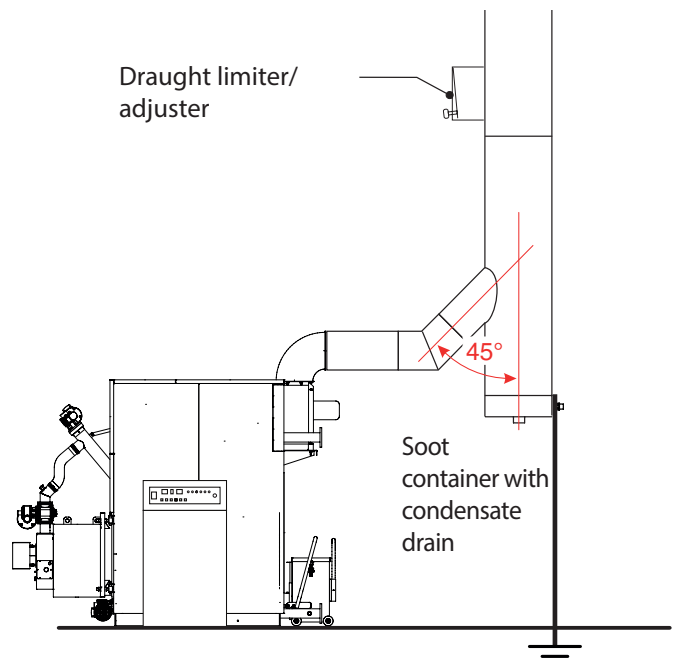

Special attention must be paid to the installation of the earthing device to protect from atmospheric electric charges. The protection is important not only for the present electronic devices but mainly for the safety of the users.

3.10.1 - EXHAUST THROUGH EXTERNAL WALL

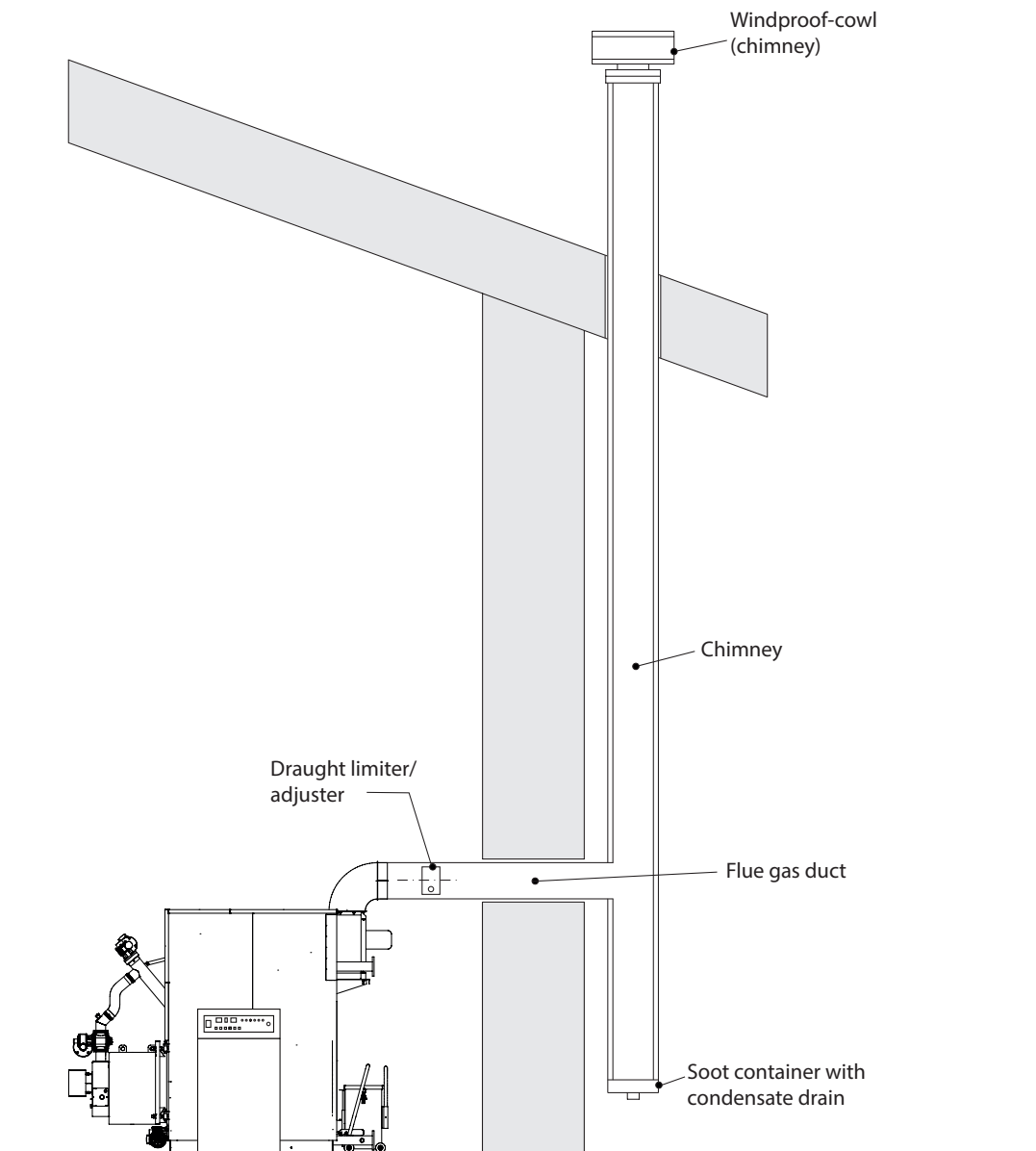

One of the installation solutions which can be adopted is that of positioning the PLT near a perimeter wall of the home so that flue gas is discharged directly outside. Here are some guidelines from the standard UNI 7129 for this particular type of configuration:

- Always provide an inspection valve which allows you to perform efficient and periodical cleaning as well as draining any condensation formed;
- The chimney must be strictly weatherproof;
- Insulate the flue gas exhaust pipe in the section passing through the wall appropriately.

The flue gas exhaust pipe, if completely outside, should be made in double wall stainless steel to guarantee both greater resistance to atmospheric agents and a sufficient flue gas temperature.

3.10.2 - EXHAUST THROUGH ROOF BY MEANS OF TRADITIONAL CHIMNEY

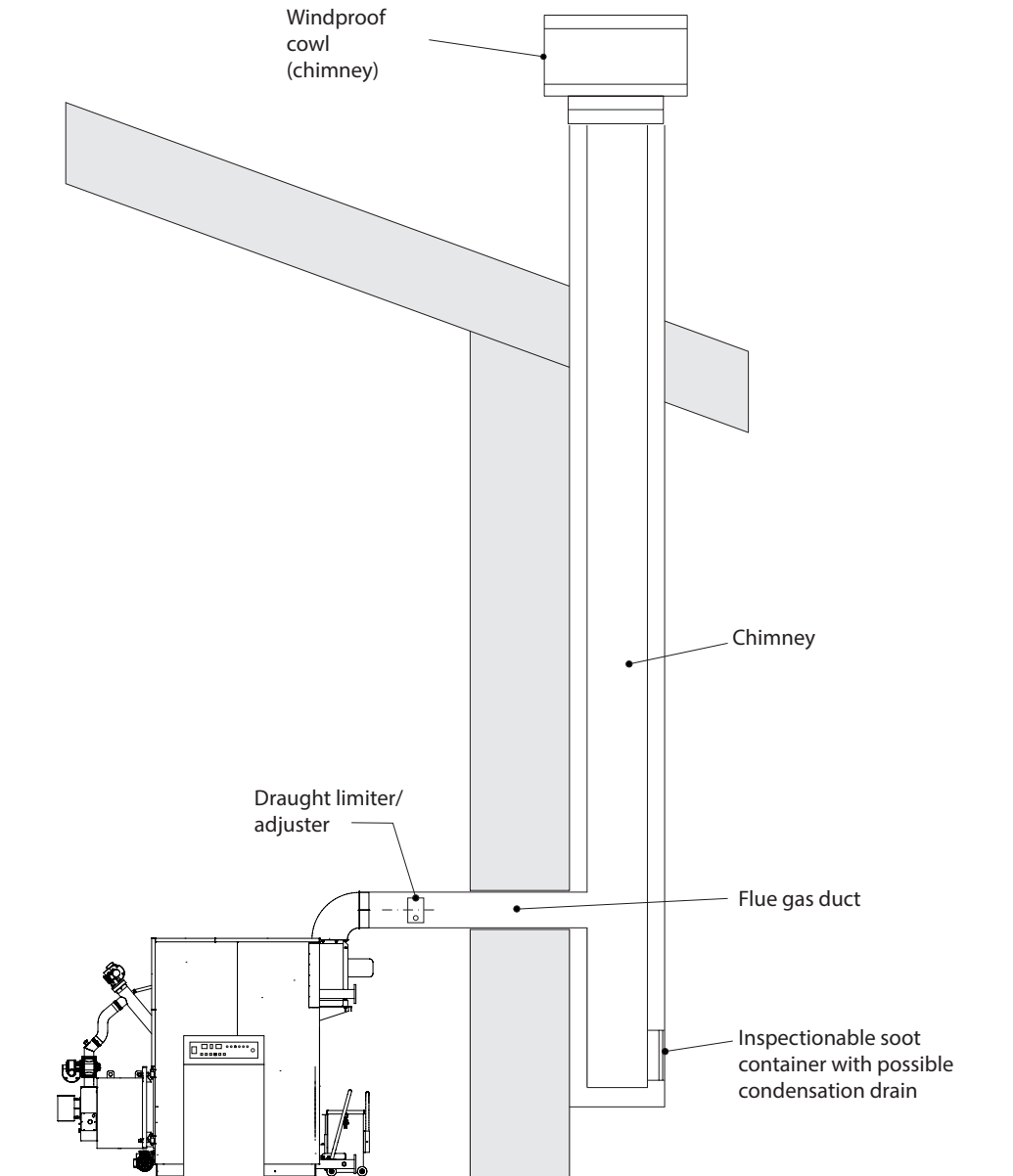

The pellet combustion flue gas can also be discharged using a traditional pre-existing flue as long it is made to standard (see UNI 10683).

We will briefly list some of the main features highlighted by the standard which characterise a good chimney:

- Adequate insulation especially in the outside section exposed to the atmosphere;
- Constant internal cross-section (there must be no cross-section constrictions);
- Made with material resistant to high temperatures, to the action of combustion products and to the corrosive action of condensation which could be formed;
- Predominately vertical with deviations no greater than 45°;

It is recommended to provide a solid material and/or condensation collection chamber which can be inspected through an airtight door.

It is recommended to abide by that established by standards UNI 9615 and 9731 for the dimensioning of the chimney cross-sections and anyhow not to make pipes with a cross-section less than 100 mm.

If there are larger cross-sections, a steel pipe must be inserted inside the masonry duct.



The steel pipe must be sufficiently insulated with high temperature resistant material and sealed from the outer chimney.

3.11 - ELECTRICAL CONNECTIONS

General warnings

The electrical safety of the appliance is guaranteed only when it has been properly connected to an efficient earthing system carried out as intended by safety standards in force: pipes of the gas, water and heating systems are absolutely unsuitable as earthing connections.

It is necessary to verify this fundamental safety requirement. If in doubt, have the electric system carefully checked by professionally qualified personnel as the manufacturer is not liable for damage caused by failure to provide an earthing system.

Have professionally qualified personnel check that the electric system is adequate for the maximum power absorbed by the appliance, indicated on the data plate. Make sure in particular that the cross-section of the cables is suitable for the power absorbed by the appliance.

Adapters, multiple sockets and/or extension cords cannot be used to power the appliance.

Use of any type of component using electric energy requires the observance of some fundamental rules, such as:

- do not touch the appliance with wet and/or moist parts of the body and/or in bare feet;
- do not pull the electric cables;
- do not leave the appliance exposed to atmospheric agents (rain, sun, etc.) unless expressly designed;
- do not allow children or unskilled persons to use the appliance.

Electric power supply connection

Electrical connections are shown in section 3.12.

Boiler installation requires electrical connection to mains at:
230 V - 50 Hz for the panel board
400 V: feeding screw and rotary valve supply

This connection must be set up according to standard, as intended by current IEC regulations.



Danger!

Only a qualified technician may perform the electrical installation.

Before performing connections or any type of operation on electrical parts, always disconnect electrical power and make sure that it cannot be reconnected accidentally.



Warning!

Upstream of the 400V power supply, install 3 4A fuses to protect any short circuits.

Remember that a bipolar switch must be installed on the boiler power line with over 3 mm between contacts, easy to access, making maintenance quick and safe.

The power cable must be replaced by authorised technical personnel. Failure to comply with the above can jeopardise the safety of the appliance.



Attention!

- Before opening the panel board, move the switch (11) to pos. "0"!
- Do not connect loads to the panel board which absorb more than 6A overall!

Approvals

The UNICAL panel board for PLT boilers has been EC approved according to standard EN 60335-1.



Technical data plate and serial number of the panel board.

The identification plate of the panel board is glued on the base.



Use

This panel board must be used to operate a boiler intended to heat water at a temperature which does not exceed the boiling point when installed.

3.12 - Panel board wiring diagrams

Panel board

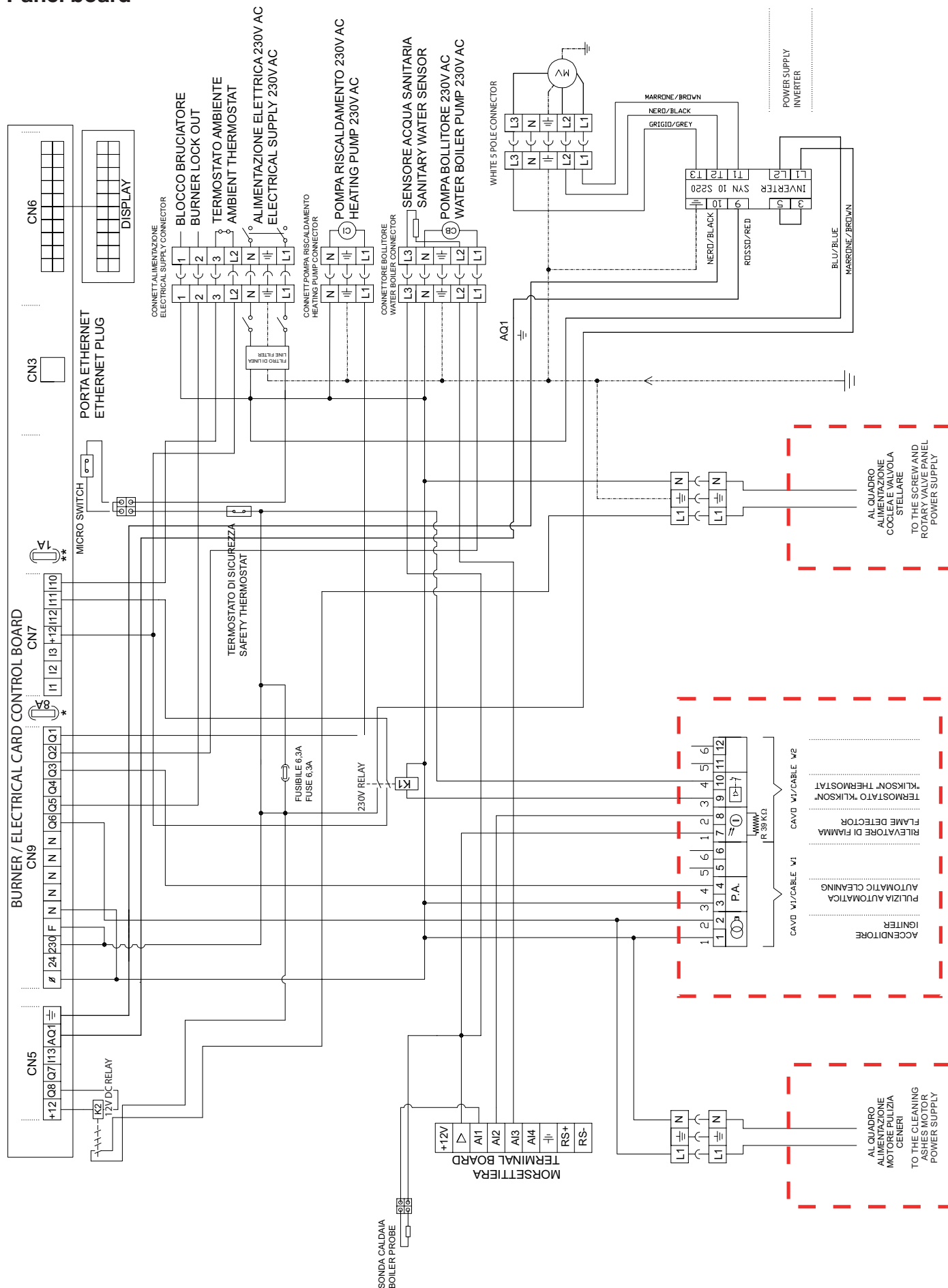

Burner wiring

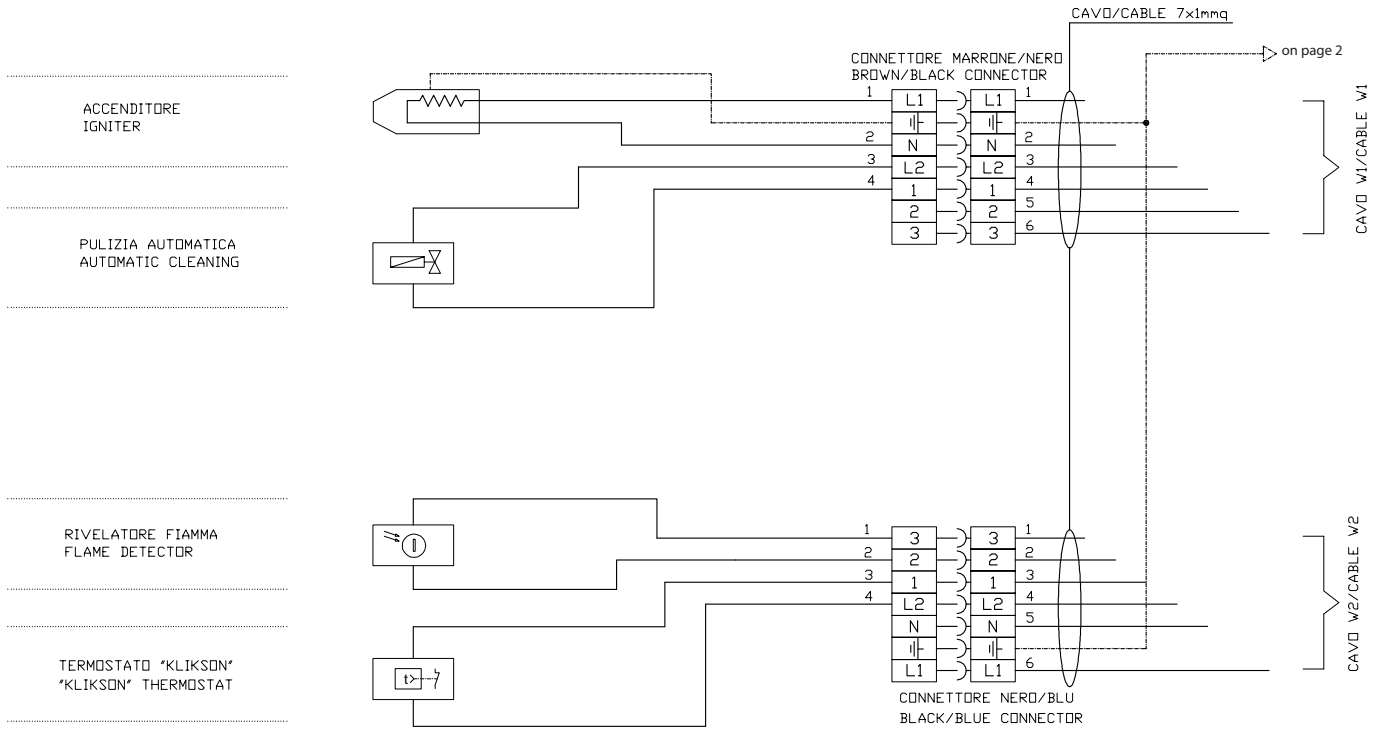

Feeding screw supply board, rotary valve, ash cleaning and smoke pipes cleaning

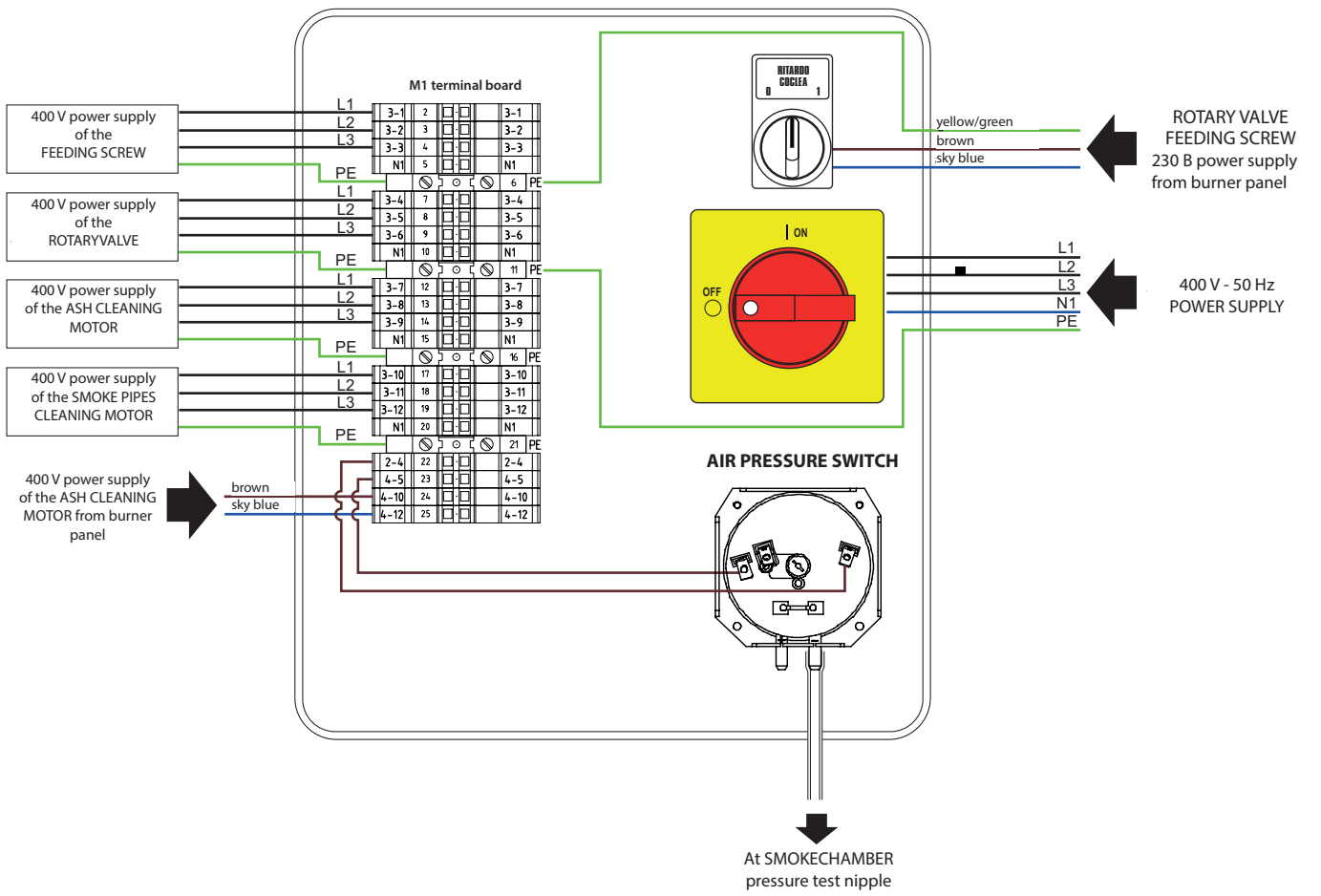

Installation instructions

No pressure test nipple connection prevents the loading feeding screw from operating, locking the boiler due to no ignition.

3.13 - PANEL BOARD

3.13.1 - DESCRIPTION

Set up for management of the burner, boiler and potential storage tank for domestic hot water production. Connection to an external chronothermostat is possible for heat adjustment of the rooms and to obtain a remote warning of the alarms. All electrical connections of the equipment are pre-wired to make burner installation on the generator operations fast. In the front panel, a membrane keyboard is inserted for programming and managing the various functions of the burner.

On the display and by means of a LED signalling system, it is possible to display the set parameters, operating status, temperature measurements detected by the boiler water and storage tank water probe, alarms. Use of the control electronic equipment is simple and immediate even by the user. For burners equipped with automatic cleaning, the timer for forced extinction and restart is standard. It is possible to maintain the burner power levels fixed at the calibration stage of the combustion and to adjust the sensitivity of the photoresistor via software directly from the keyboard.

3.13.2 - KEYS AND SIGNALS

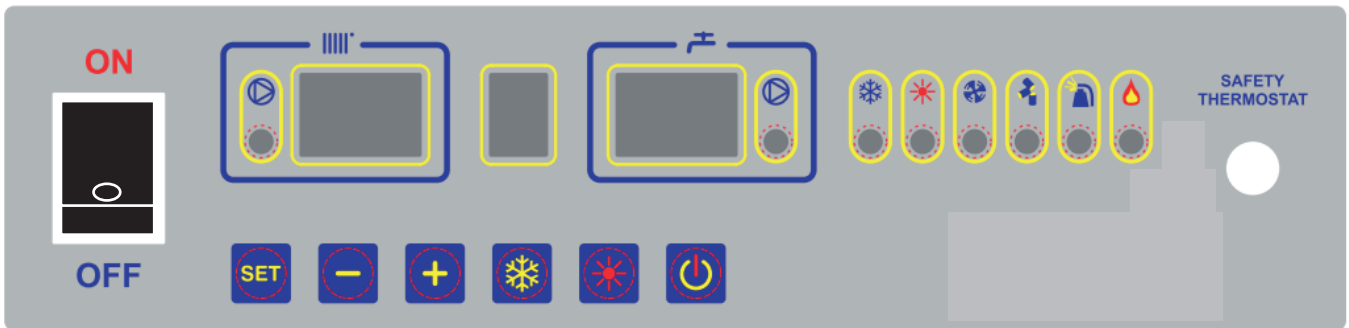

On the programmer front panel, in addition to the control keys, there are three displays, two for displaying the system temperatures (left boiler, right dhw) and one for signalling the operating stages and any faults (central display).

KEYS



1. Key to power the boiler on/off



2. Key to select programmer configuration pages.



3. Pressing this key after selecting a parameter lets you decrease its value.



4. Pressing this key after selecting a parameter lets you increase its value.

Holding down this key for 5 consecutive seconds, with programmer OFF, manually activates the pellet feeding screw. Feeding screw operation is interrupted by releasing the key.



5. Key to select system operation in "WINTER" mode.



6. Key to select system operation in "SUMMER" mode.

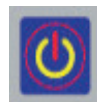

7. Pressing this key for 3 seconds starts the burner. Pressing this key for 3 seconds, during operation stage, turns of the burner. Pressing this key for 3 seconds, following burner lock, resets the alarm

LED AND DISPLAY

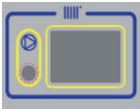

1. The light LED signals activation of the system pump and the display of the system temperature.



2. Central display: Signals the operating stages and inside a programming stage, where required, displays the third digit.

EXAMPLE: 1) Parameter number: 01; B)Parameter value: 131.

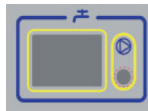
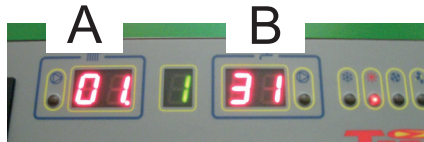

3. The light LED indicates activation of the storage tank pump. The display indicates DHW temperature.



4. "WINTER" operating mode signal



5. "SUMMER" operating mode signal



6. Fan operation signal



7. Feeding screw operation signal



8. Igniter operation signal



9. Flame presence signal.

3.13.3 - Ignition

1) Power on the board, using the ON-OFF switch.



2) After a few seconds the identification writing of the program version installed on the control board shall appear. The identification signal of the program remains active for a few seconds.

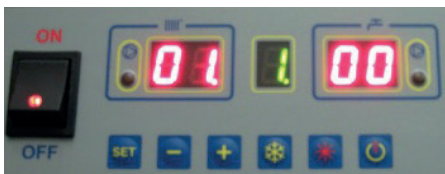

3) The display shows the instantaneous temperatures: system water flow rate (left) and dhw temperature (right).



4) Check that the burner is OFF:

To do so you must check that on the central display on the bottom right a point is not shown.

To turn the board OFF, hold down the  button for 3 seconds.

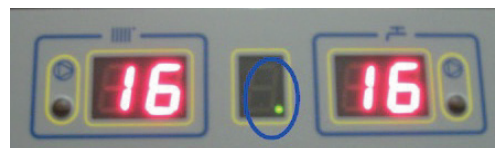

While the burner is OFF, in order to trigger the feed auger, rotate the screw selector on the telescopic frame to position

1 and hold down the  key to activate the feed auger.

Hold down the loading key  until the auger is triggered and the first pellet begins to fall into the burner.

After the pellet trigger procedure has finished, set the screw selector to the 0 position.

This procedure must be repeated every time the screwdriver is disengaged.



3.13.4 - Programming procedure for the user

The parameters available for the user for operation adjustment are provided below. Entering the password is not required to access these parameters.

Boiler temperature adjustment

From the previous screen:

- Press the “SET” key once to access system temperature.
- To increase or decrease the value set, press the “-” and “+” buttons



Values range which may be set: Min. 15°C Max. 95°C
Recommended value 75°C

Storage tank temperature adjustment

The right display shows storage tank temperature.

From the previous screen:
From the previous screen:

- Press the “SET” key once to access system temperature.
- To increase or decrease the value set, press the “-” and “+” buttons

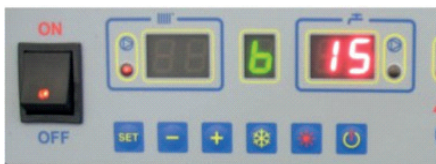

Values range which may be set: Min. 15°C Max.95°C
Recommended value 45°C

Thermal output modulation field adjustment (dF parameter)

Instructions to change the thermal output modulation field (“dF” parameter)

The burner is modular on 5 output levels where each level corresponds to a different thermal output delivered. When the burner reaches near the temperature set by the user, the panel board operates and correct burner output scaling it to a lower level. The output delivered by the burner is therefore progressively reduced when approaching the desired temperature until stopping after reaching it. The “dF” parameter defines the modulation field, meaning the temperature threshold from which the burner starts to modulate its output.

Example:
dF = 5;

It means that at -5° of the temperature set in Section 6.3.1, the burner starts to modulate the output and at each °C temperature increase corresponds a decrease in a output level.

dF = 10;

The burner begins to modulate - 10° from the desired temperature and, to each 2 °C increase in temperature, corresponds a drop in output level.

From the previous screen:

- Press the “SET” key one more time to access the modulation field parameter . The left display, shall show the “dF” symbol.
- To increase or decrease the value set, press the “-” and “+” buttons



Values range which may be set: Min. 5° Max. 20°

Maximum output adjustment (Pt parameter)

Instructions to set maximum output used by the burner.

The burner operates on 5 output levels. Level 5 corresponds to maximum output, level 1 corresponds to the minimum output. By modifying the Pt parameter, the user can decide the maximum output level used by the burner.



Burner output levels are set by the installation technician during commissioning. The installer must calibrate the feeding screw and set the feeding screw operating frequency and fan speed for each of the 5 output levels.

From the previous screen:

- Press the “SET” key one more time to access the Pt parameter.
- To increase or decrease the value set, press the “-” and “+” buttons



Values range which may be set: Min.1; Max 5;

Access to the installer parameter list

To access the installer parameter list (See Section 3.17.1) entering the password is required.

- Enter the password and press the “SET” button to confirm.

From the previous screen:

- Press the “SET” key one more time to access the P parameter.



3.13.5 - Description of programmer operation stages

Burner operation consists in 7 stages:

STAGE	SYMBOL	ALARM
FAN	F	Initial stage: Cleaning the combustion chamber via the fan drive and activating the automatic cleaning systems. <ul style="list-style-type: none"> • Igniter OFF; • Pellet feeding screw OFF; • Photoresistor active; • Fan motor at maximum speed; • Automatic cleaning ON; (If equipped)
LOAD	L	Loading stage: A preset pellet quantity is loaded from the feeding screw to the burner. The igniter starts the heating stage. <ul style="list-style-type: none"> • Igniter ON; • Pellet feeding screw ON for the time set; • Photoresistor inactive; • Fan motor inactive;
IGNITION	I	Ignition stage: The igniter triggers the combustion <ul style="list-style-type: none"> • Feeding screw OFF; • Igniter ON; • Photoresistor active and checks flame presence; • Fan motor turns at set speed;
STAB	S	Stabilisation stage: Stage required at fuel ignition and flame stabilisation process completion. <ul style="list-style-type: none"> • Igniter OFF; • Pellet feeding screw ON; • Photoresistor active and checks flame presence; • Fan motor ON;
HEAT	H	Heating stage: The burner operates at full capacity. Pellet capacity changes based on the output required. Combustion air is adjusted by the fan according to the speed parameters set in order to obtain the best combustion possible. <ul style="list-style-type: none"> • Igniter OFF; • Pellet feeding screw ON; • Photoresistor active and checks flame presence; • Fan motor ON;
COOL	C	Cooling stage: The burner gradually turns off via continuous ventilation and interruption of loading other pellets. <ul style="list-style-type: none"> • Igniter OFF; • Pellets feeding screw OFF; • Photoresistor active and checks flame presence; • Fan motor ON;
GOOD	-	The display shows the “. “ symbol when the boiler or storage tank temperature has been reached. The boiler only restarts after boiler or storage tank temperature has dropped below the differential temperature set



ATTENTION!
PROGRAMMER OPERATION IS ADJUSTED, IN ADDITION TO USER PARAMETERS LISTED IN THE PREVIOUS PARAGRAPH, ALSO BY A SERIES OF PARAMETERS, EACH OF WHICH MAY BE CHANGED BY TECHNICAL SUPPORT FROM A MINIMUM VALUE TO A MAXIMUM VALUE, TO PERFORM BURNER CALIBRATION AT THE MOMENT OF INSTALLATION

3.14 - BOILER START-UP

3.14.1 - PRELIMINARY CHECKS



Commissioning must be done by professionally qualified personnel. Unical will not be held liable for damage to persons, animals or objects due to failure to comply with the aforesaid instructions.

The preliminary checks must be carried out by the installation firm.

After connecting the hydraulic and electrical system and the fuel line to the boiler, and before starting up the boiler, it is advisable to check the following:

	YES	NO
Have all the hydraulic and electrical systems and the safety devices been connected in compliance with the domestic and local laws in force?	<input type="checkbox"/>	<input type="checkbox"/>
Are the expansion vessel and the safety valve (when applicable) connected correctly and cannot be shut off?	<input type="checkbox"/>	<input type="checkbox"/>
Are the bulbs of the operating, safety, minimum thermostats and that of the thermometer inserted in their conduits?	<input type="checkbox"/>	<input type="checkbox"/>
Are the control and safety devices working and configured correctly?	<input type="checkbox"/>	<input type="checkbox"/>
Are the refractory coverings intact?	<input type="checkbox"/>	<input type="checkbox"/>
Is the grate of the burner installed correctly?	<input type="checkbox"/>	<input type="checkbox"/>
Are the combustion air adduction line and the flue gas evacuation line compliant with the applicable standards in force?	<input type="checkbox"/>	<input type="checkbox"/>
are the mains voltage and frequency compatible with the burner and the electrical equipment of the boiler?	<input type="checkbox"/>	<input type="checkbox"/>
Is the system full of water and does not contain any air?	<input type="checkbox"/>	<input type="checkbox"/>
are the drain valves closed and the system shut-off devices fully open?	<input type="checkbox"/>	<input type="checkbox"/>
Is the outside main switch ON?	<input type="checkbox"/>	<input type="checkbox"/>
Is the pump/are the pumps working correctly?	<input type="checkbox"/>	<input type="checkbox"/>
has the system been checked for water leaks?	<input type="checkbox"/>	<input type="checkbox"/>
are the ventilation conditions and minimum distances to perform any maintenance guaranteed?	<input type="checkbox"/>	<input type="checkbox"/>
has the operator been trained and has the documentation been supplied?	<input type="checkbox"/>	<input type="checkbox"/>

Please tick the operations performed

3.15 - COMMISSIONING



ATTENTION
THIS OPERATION MUST BE CARRIED OUT
BY QUALIFIED AND TRAINED TECHNICAL
STAFF.

1. Check that all electrical and mechanical connections have been correctly performed

Also check the clockwise rotation of the following components:

- fan (seen from behind)
- the loading auger (seen from above)
- the stellar valve
- the ash compactor motor (seen from the front)
- the turbocharger shaker motor

2. Fill the storage tank with the pellet;
3. Turn the panel board on and check that the display is on;
4. While the burner is OFF, in order to trigger the feed auger, rotate the screw selector on the telescopic frame to position 1 and hold down the “+” key to activate the feed auger.
 Hold down the loading key “+” until the auger is triggered and the first pellet begins to fall into the burner.
 After the pellet trigger procedure has finished, set the screw selector to the 0 position.
 This procedure must be repeated every time the screw-driver is disengaged.
5. Start programming by pressing the “SET” key No. 2 and if required, change the parameters selected by following the specific procedures;
6. Exit the programming stage by holding down the “SET” key for 2 consecutive seconds;

7. Press the key No.7 for 3 seconds to turn on the burner;
8. Check that the burner turns on correctly within times compliant with the standard (3 or 4 minutes) and without excessive smoke. If not adjust the parameters regarding ignition (fuel pre-load and/or fan speed);
9. On ignition occurred check that:
 - The flame during stabilisation stage is yellow. Check that the photoresistor correctly detects flame presence. In case of detection issues, adjust photoresistor sensibility by lowering the activation threshold (sensibility increase);
 - If the flame is blue, lower fan speed in stabilisation stage or increase the fuel quantity in stabilisation stage;
10. When the burner is in HEAT stage, perform a combustion analysis for each output level set in order to obtain the best combustion possible by adjusting the air;
11. Measure the pressure in the combustion chamber to be sure it corresponds to the correct application standards;
12. Compressed air station pressure adjustments calibration:
 - Cleaning accumulator: accumulator pressure must be adjusted based on the type and quantity of fuel ash. Maximum value to not exceed = 4 bar.
13. Check correct pumps operation;
14. Check that the system reaches the temperature set;
15. During burner extinction stage check that, once the flame is off, the photoresistor no longer detects its presence.

LED	CONTROL	ACTION
	LED on with no presence	Increase the photoresistor lower threshold value parameter. (below this value the photoresistor does not detect flame presence)
	LED off with flame presence.	Decrease the photoresistor upper threshold value parameter. (above this value the photoresistor detects flame presence).



Calibrate fuel flow rate based on the output required by the heat generator.

Calibrate the combustion air/fuel ration in order to develop a correct combustion and obtain efficiency at least equal to the minimum required by the regulations in force.

Check correct operation of the adjustment and safety devices.

Check correct operation of the combustion products exhaust duct.

At the end of calibration operations check that all adjustment mechanical systems are locked. Perform an on sight inspection to check correct tightening of screws and bolts.

3.16 - BURNER EXTINCTION

Pressing the  key for 3 seconds, the burner immediately goes in extinction stage interrupting pellet supply.



IN CASE OF FAILURE AND/OR MALFUNCTIONING OF THE APPLIANCE, SWITCH IT OFF OR DO NOT TRY TO REPAIR IT OR OPERATE ON IT DIRECTLY. EXCLUSIVELY CONTACT PROFESSIONALLY QUALIFIED PERSONNEL. ANY REPAIRS MUST BE PERFORMED USING ORIGINAL SPARE PARTS.

3.17 - INSTRUCTIONS FOR TECHNICAL SUPPORT

To access the protected parameters page, request the password from the manufacture.

The password to access adjustment parameters control is only released to technical and trained personnel.

3.17.1 - PARAMETERS SETUP

Burner operation is adjusted by a series of parameters which enable to optimise and change its operation.

Each panel board leaves the factory with parameters already set based on the burner model and based on the application. The installer shall, during commissioning and following maintenance, appropriately adjust the burner based on the characteristics of the fuel and of the thermal unit on which it is installed.



The user must always use the same type of fuel with which the calibration has been performed. Should changing fuel type be required, calibration must be re-performed. Failure to comply with this rule entails possible drop in system performance due to different fuel quality.



During “STAB” and “HEAT” stage (See 3.15.5) the pellet feeding screw “ON” time to be set is entered inside a 16 seconds fixed cycle. For example, if we set an “ON” time of 10 seconds, the feeding screw shall remain active for 10 seconds and shut down (“OFF”) for 6 seconds. This shall occur cyclically until burner extinction.

Panel board parameters list

Parameter	Stage	Description	Min value settable	Max. value settable	Unit	PLT 250
PR01	LOAD	Defines the total time of the LOAD stage (stage in which resistor heating and pellet loading on the gassification grate occurs).	10	255	SECONDS	45
PR02	IGNITION	To change from stage (I) to stage (S), the photoresistor must detect flame presence for 20 consecutive seconds. PR02 defines the maximum number of minutes allowed to detect flame presence. If the burner does not detect the flame within the time set, the burner goes in alarm ("no fire" alarm)	1	20	MINUTES	8
PR03	FAN	Automatic cleaning solenoid valve energising time	1	10	SECONDS	5
PR04	LOAD	Pellet loading for ignition time	1	255	SECONDS	30
PR05	STAB	Feeding screw in stabilisation ON time.	1	16	SECONDS	3.5
PR06	HEAT	Feeding screw at output 1 ON time	1	16	SECONDS	3.5
PR07	HEAT	Feeding screw at output 2 ON time	1	16	SECONDS	5.6
PR08	HEAT	Feeding screw at output 3 ON time	1	16	SECONDS	7.6
PR09	HEAT	Feeding screw at output 4 ON time	1	16	SECONDS	9.6
PR10	HEAT	Feeding screw at output 5 ON time	1	16	SECONDS	11.3
PR11	ALL	Alarms entering delay	5	240	SECONDS	5
PR12	STAB	Stabilisation stage duration time. Parameters which defines the time in which the burner stabilises the flame.	55	255	SECONDS	255
PR13		Boiler thermostat differential temperature	1	20	C	6
PR14		Storage tank thermostat differential temperature	1	20	°C	5
PR15	F+I+S+H+C	Not operational (leave the value = 0)	****	****	****	255
PR16	STAB+HEAT	Not operational	****	****	****	120
PR17	STAB+HEAT	Not operational (leave the value = 0)	****	****	****	0.3
PR18	STAB+HEAT	Not operational	0	15	SECONDS	8
PR19	STAB+HEAT	Not operational	****	****	NUMBER	1
PR20	IGNITION	Fan motor in ignition stage speed	40	100	NUMBER	60
PR21	STAB	Fan motor in stabilisation stage speed	40	100	NUMBER	50
PR22	COOL	Fan speed in COOL stage	40	100	NUMBER	100
PR23	HEAT	Fan motor at output 1 speed	40	100	NUMBER	40
PR24	HEAT	Fan motor at output 2 speed	40	100	NUMBER	50

Parameter	Stage	Description	Min value settable	Max. value settable	Unit	PLT 250
PR25	HEAT	Fan motor at output 3 speed	40	100	NUMBER	75
PR26	HEAT	Fan motor at output 4 speed	40	100	NUMBER	90
PR27	HEAT	Fan motor at output 5 speed	40	100	NUMBER	100
PR28	HEAT	Boiler pump start minimum temperature	20	80	°C	50
PR29		Threshold value of the photoresistor for flame detection when changing from inactive photoresistor to active photoresistor.	0	999	NUMBER	250
PR30		Threshold value below which the photoresistor does not perform flame detection when changing from active photoresistor to inactive photoresistor.	0	999	NUMBER	215
PR31		Override output level: sets the desired output level and maintains it until reaching boiler set not performing modulation. Function useful in burner calibration stage.	0 (NOT ACTIVE)	5	NUMBER	0
PR32	HEAT	Automatic extinction time; after the set time interval has passed (minimum 10 minutes) the burner goes in extinction restarting automatically independently from reaching the set points of the temperatures set.	0 (NOT ACTIVE)	990	MINUTES	0

IGNITION= I LOAD = L FAN= F STAB= S COOL = C HEAT= H

3.18 - TROUBLESHOOTING

Problem:

- *The panel board does not switch on.*

Remedy:

- Make sure the panel board is powered.
- Check integrity of the fuse inside the board.

Problem:

- *The fan does not turn.*

Remedy:

- Make sure no alarm appears on the display.
- Check the power connection of the fan.
- Check whether the system is on or off.
- Check the inverter.
- Replace the fan.
- Check the safety thermostat

Problem:

- *The burner starts up but triggers an alarm shortly afterwards.*

Remedy:

- Check that the screw is feeding the pellets correctly.
- Check the condition of the pellets and replace them if necessary.

Problem:

- *The start-up process goes smoothly until pre-loading of the pellets, after which an alarm is triggered.*

Remedy:

- Check the nature of the triggered alarm.
- Check the condition of the igniters.
- Replace the igniters.

Other alarms that can occur during use of the boiler, and the measures to be taken.

Triggering of the water safety thermostat

- Check the working order of the pumps.
- Reset thermostat manually.

Triggering of the pellet fire thermostat



- Check the draught in the flue.
- Check that the smoke ducts containing the turbolators are not clogged with ash.
- Clean them if required.
- Resetting occurs automatically when the temperature detected by the thermostat falls by 10°C.



3.18.1 - Diagnostics and troubleshooting on panel board

The Programmer, via the display, has a series of functions available which enable easy and immediate diagnostics of the instrument.

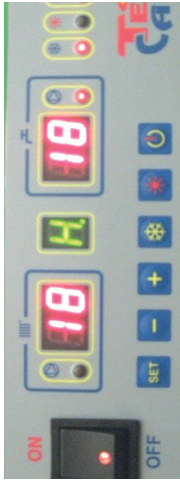
During operation:

- The left display of the programmer front panel always shows boiler water temperature.
 - The right display shows storage tank water temperature.
 - The central display shows operating stage and potential alarm type.
 - If the temperatures on the displays are reversed, check probes connection.
 - Burner ignition must occur in the "IGNITION" stage within 3-4 minutes. If the ignition time exceeds 3-4 minutes, increase cleaning operations and correct ignition parameters if required. Also check the correct operation of the igniter.
 - In case of tank emptying, reset both the tank and the feeding screw, by pressing the button No.4 to activate the fuel feeding screw and hold it down until the feeding screw is completely full.
- All alarms put set the burner to OFF, therefore after performing the alarms "RESET" manoeuvre it is required to repeat the ignition procedure by pressing the button no.7 again for 3 seconds.
- The alarm cause must be removed before performing the reset.

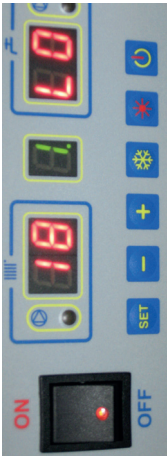
DISPLAY LEFT	DISPLAY CENTRAL	DISPLAY RIGHT	STAGE	FAULT DESCRIPTION	POSSIBLE CAUSES	OPERATIONS RESTORATION
Temperature boiler 	"I" flashing	Output level	IGNITION	Failed ignition or no flame at the end of this stage	<ul style="list-style-type: none"> No pellets; Igniter faulty; Photoresistor faulty or dirty; Programmer faulty; Burner dirty 	<ul style="list-style-type: none"> Press key No. 7 for 3 seconds. Press key No. 6 for 3 seconds again.
Temperature boiler 	"H" flashing	Output level	HEAT	No flame during operation	<ul style="list-style-type: none"> Incorrect burner calibration; No pellets; Photoresistor faulty or dirty; Programmer faulty; Burner dirty. 	<ul style="list-style-type: none"> Press key No. 7 for 3 seconds. Press key No. 7 for 3 seconds again.
Temperature boiler 	(box) flashing	Output level	during any stage	operation for high temperature of the thermostat on the pellet supply pipe. Operation of the pressure switch for combustion chamber pressure increase.	<ul style="list-style-type: none"> Boiler dirty; Chimney obstructed; Burner dirty. 	<ul style="list-style-type: none"> Press key No. 7 for 3 seconds. Press key No. 7 for 3 seconds again.
LO 	C flashing	Output level	during any stage	Boiler water temperature is < 1°C	Boiler probe faulty, disconnected or incorrectly connected;	<ul style="list-style-type: none"> Press key No. 7 for 3 seconds. Press key No. 7 for 3 seconds again.

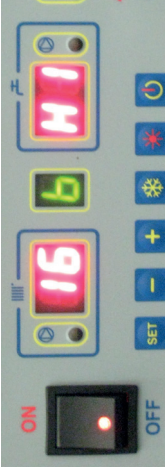
DISPLAY LEFT	DISPLAY CENTRAL	DISPLAY RIGHT	STAGE	FAULT DESCRIPTION	POSSIBLE CAUSES	OPERATIONS RESTORATION
Temperature boiler		LO	during any stage	Storage tank water temperature is < 1°C	Storage tank probe faulty, disconnected or incorrectly connected;	
						
			during any stage	Boiler water temperature exceeds 100°C	<ul style="list-style-type: none"> Boiler temperature increase; Boiler probe faulty; Programmer faulty; Board fuse faulty; 	<p>Wait for the boiler water to drop in temperature and press the safety thermostat reset button.</p>
						
"H"	"C" flashing	Output level	during any stage	Boiler water temperature exceeds > 90°C	<ul style="list-style-type: none"> Boiler water temperature increase; Boiler probe faulty; Programmer faulty; Check system carrier fluid circulation; 	<ul style="list-style-type: none"> Press key No. 7 for 3 seconds. Press key No. 7 for 3 seconds again.
						
Temperature boiler	"b" flashing	HI	during any stage	Storage tank probe short circuit	Seepage	<ul style="list-style-type: none"> Press key No. 7 for 3 seconds. Press key No. 7 for 3 seconds again.
						

4

INSPECTIONS AND MAINTENANCE



Routine maintenance is essential in the interest of the safety, efficiency and durability of the appliance.

All maintenance must be carried out by qualified personnel.

Yearly maintenance of the appliance is mandatory as laid down by the Laws in force.



Failure to perform Inspections and Maintenance can entail material and personal damage.



Always turn off the power supply and stop the supply of fuel before cleaning and maintenance.

In order to make the most of the boiler, you should properly clean the combustion chamber, smoke pipes and smoke chamber.

We therefore recommend stipulating an inspection or maintenance contract.

Inspections help to determine the actual status of the appliance and to compare it with the nominal status. This is done through measuring, controls and observation.

Maintenance is required to eliminate any differences between the actual status and the nominal status. This is normally done by cleaning, setting and replacing individual components subject to wear.

Maintenance intervals and their extent are determined by a specialist based on the status of the appliance ascertained through inspection.

Inspection and maintenance instructions

To assure long-term functioning of your appliance and to avoid altering its approved status, only original Unical spare parts must be used.

Before proceeding with maintenance, always perform the following operations:

- Disconnect the electric mains switch.
- Isolate the appliance from the electric mains by means of an isolated device with a contact opening of at least 3 mm (e.g. safety devices or power switches) and make sure that it cannot be re-connected accidentally.
- Close the shut-off valves on the heating flow and return pipes, as well as the cold water inlet valve.

After having completed all maintenance work, always perform the following operations:

- Open the heating flow and return pipes, as well as the cold water inlet valve.
- If necessary, restore the heating system pressure.
- Reconnect the appliance to the electric mains and engage the switch.
- Make sure that the appliance is watertight.
- Vent the heating system and restore pressure if necessary.

EXCHANGER BODY MAINTENANCE



Danger!

Before performing any maintenance on the boiler, make sure the boiler and its components have cooled down.

Warnings

Never drain water from the system, even partially, unless absolutely necessary.

Periodically check the proper operation and integrity of the flue gas exhaust pipe and/or device.



Do not clean the boiler and/or its parts with easily flammable substances (e.g. petrol, alcohol, etc.).

Do not leave flammable substances in the room where the boiler is installed.

At the end of each heating period, inspect the boiler to keep the system in perfect efficiency.

Proper maintenance is essential in the interest of economy and safety.

IMPORTANT

Regularly check the parts of the burner that can be dirtied as a result of the quality of the pellets or of poor control of combustion.

Clean with brushes and a vacuum cleaner; if you use any rags, make sure you collect all these.

Keeps the screws and nuts lubricated.

CLEANING AND ROUTINE MAINTENANCE

Every day

- Fill the pellet tank
If the boiler is not equipped with an automatic loading system, the pellet hopper must be filled several times.

Every 3 days

- Remove ashes in the ash collection pan.
- To perform this operation, act as follows:
- turn off the power at the main switch upstream of the boiler;
 - unplug the burner and pressure switch;
 - open the doors of the boiler by undoing the nuts with the spanner provided;
 - use a suitable vacuum cleaner to carefully remove all combustion residue in the boiler;
 - put the pan back in place and check the integrity of the refractory material;
 - remove ashes from the smoke chamber through the rear door;
 - check the condition and correct fixing of the pellet feeding hose.

Every 20 days

Check the level of the ashes in the compactor.

Every month

In addition to the weekly maintenance, clean the upper passages of the combustion chamber with the brush supplied after having removed and cleaned all the smoke diverters. Replace the diverters in their seats alternating them. Also check the condition of the sealing gaskets on the doors and on the smoke chamber.
Open the burner door and check the if the burner grill itself is clean.

YEARLY MAINTENANCE

Refer to the table on the next page

**ATTENTION!**

Perform the following maintenance operations at least once a year. In case of seasonal service we recommend performing maintenance at the end of each heating season. In case of continuative service maintenance must be performed every 6 months.

MAINTENANCE OPERATIONS	Every year
Feeding screw reducer	X
Check preloading of the expansion vessel	X
Condition of pellet feeding hose	X
Fan: general overhaul and inspection of the state of the impeller, cleaning and lubricating the bearings, and that the impeller spins freely	X
Check the hermetic seal of the doors	X
Make sure that the sealing gaskets are intact	X
Check the operation of the safety devices	X
Clean the smoke ducts	X
Make sure that the refractory stones are intact	X
Check wear, cleanliness and repositioning of the burner grate	X
Lubricate/grease the hinges and door opening levers	X
Thorough cleaning of the furnace and smoke ducts, removing any build-up and soot	X
Calibrate the draught adjuster	X
Cleaning and checking correct operation of flame detection photoresistor	X
Check the correct operation of the igniter	X
Emptying and cleaning the pellet container	X
Checking the status of electrical supply cables and of interface electrical connectors	X

Unical[®]



www.unical.eu

Unical AG S.p.A. 46033 Casteldario - Mantua - Italy - tel. +39 0376 57001 - fax +39 0376 660556
info@unical-ag.com - export@unical-ag.com - www.unical.eu

Unical shall not be held liable for any inaccuracies due to transcription or printing errors.
Furthermore, it reserves the right to modify its products as deemed necessary or useful, without affecting their essential features.